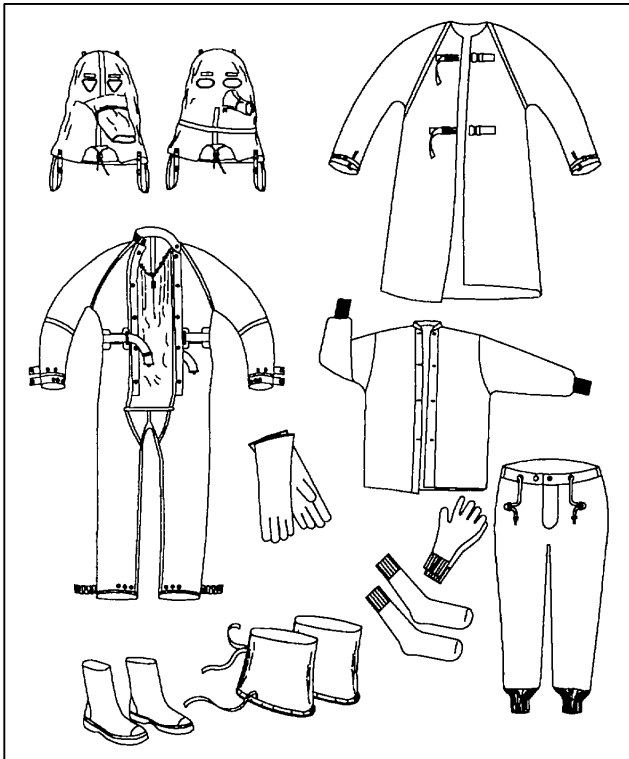


TECHNICAL MANUAL

OPERATOR'S, UNIT AND DIRECT SUPPORT
 MAINTENANCE MANUAL
 INCLUDING REPAIR PARTS AND SPECIAL TOOLS LIST
 FOR THE
 TOXICOLOGICAL AGENT PROTECTIVE (TAP) ENSEMBLE



CHAPTER 1 INTRODUCTION.....	1-1
--------------------------------	-----

CHAPTER 2 OPERATING INSTRUCTIONS	2-1
---	-----

CHAPTER 3 OPERATOR MAINTENANCE	3-1
---	-----

CHAPTER 4 UNIT MAINTENANCE	4-1
-------------------------------------	-----

CHAPTER 5 DIRECT SUPPORT MAINTENANCE.....	5-1
--	-----

APPENDIX A REFERENCES	A-1
--------------------------------	-----

APPENDIX B MAINTENANCE ALLOCATION CHART (MAC)	B-1
---	-----

APPENDIX C REPAIR PARTS AND SPECIAL TOOLS LISTS	C-1
---	-----

APPENDIX D COMPONENT OF END ITEM LIST	D-1
--	-----

APPENDIX E ADDITIONAL AUTHORIZATION LIST... ..	E-1
---	-----

APPENDIX F EXPENDABLE DURABLE SUPPLIES AND MATERIALS LIST.....	F-1
--	-----

APPENDIX G ILLUSTRATED LIST OF MANUFACTURED ITEMS.....	G-1
--	-----

GLOSSARY.....	GLOSSARY-1
---------------	------------

ALPHABETICAL INDEX.....	Index 1
-------------------------	---------

WARNING

- The following doffing procedures are to be used only when TAP Ensemble has not been exposed to contamination. For decontamination procedures, refer to FM 3-5 or DA Pam 385-61.
- Use maintenance kit adhesive in a well ventilated area only and avoid skin contact. Wear proper protective equipment. Failure to do so may result in light-headedness or a burning sensation to the eyes and skin. In case of skin contact, wash with soap and water. If vapors become strong, leave the area and allow to ventilate.
- Toluene is extremely flammable and its vapors toxic. Use toluene in a well ventilated area away from any source of heat. Death or severe injury may result from explosion, fire or fume inhalation. If vapors become strong, leave area and allow to ventilate. In case of skin contact, wash with soap and water.
- FIRE HAZARD. Ensure clothing outfit is completely dry before packaging. Compressing clothing outfit while damp can cause spontaneous combustion. Failure to observe this warning may result in severe injury or death.
- Butyl rubber impermeable protective clothing will burn and does not possess self-extinguishing properties. Therefore, contact with open flame or objects which would ignite the clothing must be avoided. Smoking is prohibited in the vicinity of or while wearing butyl rubber TAP items. Failure to observe this warning may result in severe injury or death.

- **Surgical gloves will not be worn in operations involving M55 rockets outside their shipping and firing tubes, and in operations where exposed explosives or propellants are present or where a hazard analysis indicates electrostatic initiation is possible. Severe injuries may occur.**
- **Personnel, tools and equipment must be properly grounded when working near static sensitive munitions, exposed explosives, or hazardous concentrations of flammable dusts, gases or vapors. Failure to use proper procedures could result in death or injury.**
- **Personnel contamination hazard. Protective suit should be thoroughly inspected for cracks in cold weather environments. Cracks are more likely to develop in cold, stiff suit material. If cracks are detected, repair or replace the protective suit. Failure to repair a damaged suit could result in death or severe injury due to contamination.**
- **Personnel contamination hazard. All equipment must be decontaminated after exposure to chemical agents. Failure to decontaminate properly could result in death or personnel injury due to contamination.**
- **Personnel contamination hazard. Do not touch the outside of the protective suit during doffing. Always fold it outward, away from the body. Failure to doff the suit properly could result in death or injury due to contamination.**
- **Heat stress hazard. At any sign of nausea, dizziness, or difficulty in breathing, leave the area immediately and cool off. Failure to leave the area and cool off could result in**

- Users of TAP ensemble should be given sufficient recuperation time between operations in hot weather environments to avoid heat exhaustion. Fatigue, nausea and/or dizziness could result from extended use without adequate rest and fluid replenishment.

c/(d blank)

TECHNICAL MANUAL
OPERATOR'S, UNIT, AND DIRECT SUPPORT
MAINTENANCE MANUAL
INCLUDING REPAIR PARTS AND SPECIAL TOOLS LIST
FOR
TOXICOLOGICAL AGENT PROTECTIVE (TAP) ENSEMBLE

REPORTING ERRORS AND RECOMMENDING IMPROVEMENTS

You can help improve this manual. If you find any mistakes or if you know of a way to improve the procedures, please let us know. Mail your letter, DA form 2028 (Recommended Changes to Publications and Blank Forms, or DA form 2028-2, located in the back of this manual) direct to: Commander, U.S. Army Aviation and Troop Command, ATTN: AMSAT-I-MP, 4300 Goodfellow Blvd. St. Louis, MO 63120-1798. A reply will be furnished to you.

DISTRIBUTION STATEMENT A: Approved for public release; distribution is unlimited

TABLE OF CONTENTS

	page
CHAPTER 1. INTRODUCTION.....	1-1
Section I. GENERAL INFORMATION.....	1-1
1-1. SCOPE.....	1-1
1-2. MAINTENANCE FORMS AND PROCEDURES.....	1-1
1-3. DESTRUCTION OF ARMY MATERIEL TO PREVENT ENEMY USE.....	1-1
1-4. PREPARATION FOR STORAGE OR SHIPMENT.....	1-1
1-5. QUALITY ASSURANCE (QA).....	1-1
1-6. NOMENCLATURE CROSS-REFERENCE LIST.....	1-1
1-7. REPORTING EQUIPMENT IMPROVEMENT RECOMMENDATIONS (EIR).....	1-2
1-8. CORROSION PREVENTION AND CONTROL.....	1-2
1-9. LIST OF ABBREVIATIONS.....	1-2
Section II. EQUIPMENT DESCRIPTION.....	1-2
1-10. EQUIPMENT CHARACTERISTICS, CAPABILITIES, AND FEATURES.....	1-2
1-11. LOCATION AND DESCRIPTIONS OF MAJOR COMPONENTS.....	1-3
1-12. DIFFERENCES BETWEEN MODELS.....	1-5
1-13. EQUIPMENT CONFIGURATION.....	1-5
Section III. PRINCIPLES OF OPERATION.....	1-5
1-14. CHEMICAL AND BIOLOGICAL PROTECTION.....	1-5

TABLE OF CONTENTS

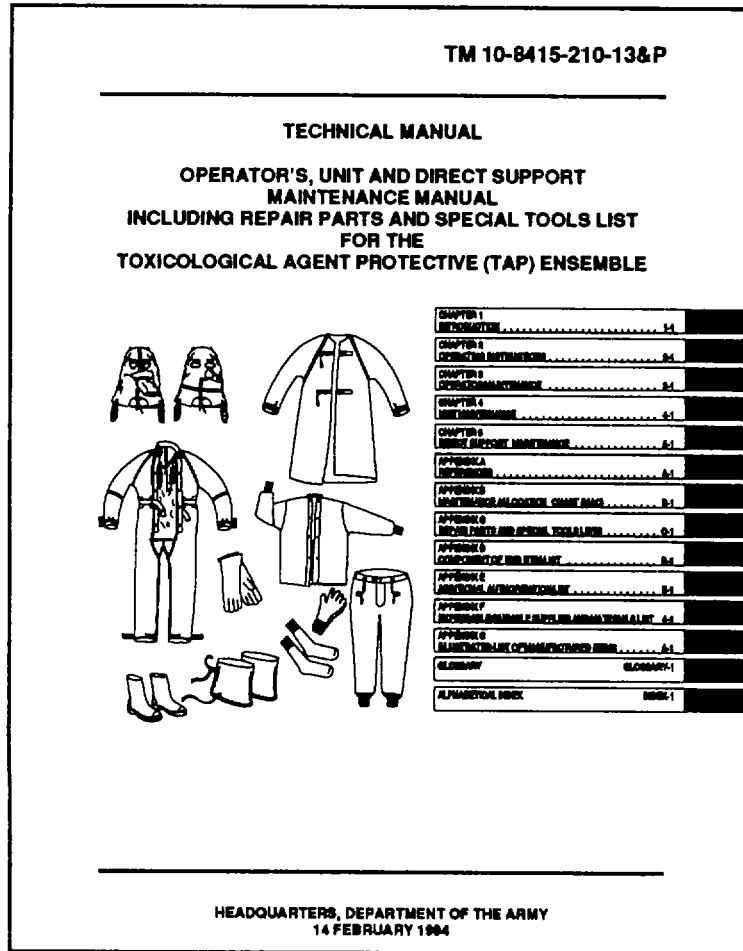
	page
CHAPTER 2. OPERATING INSTRUCTIONS.....	2-1
Section I. PREVENTIVE MAINTENANCE CHECKS AND SERVICES (PMCS).....	2-1
2-1. INTRODUCTION TO PMCS TABLE.....	2-1
Section II. OPERATION UNDER USUAL CONDITIONS.....	2-16
2-2. ASSEMBLY AND PREPARATION FOR USE.....	2-16
2-3. LEVELS OF PROTECTION AND APPLICABILITY OF TAP ENSEMBLE COMPONENTS.....	2-16
2-4. DORNING TAP ENSEMBLE FOR LEVEL A.....	2-17
2-5. DORNING TAP ENSEMBLE FOR LEVEL B.....	2-21
2-6. DORNING TAP ENSEMBLE FOR LEVEL C AND D.....	2-23
2-7. DOFFING COMPLETE TAP ENSEMBLE.....	2-24
2-8. DOFFING TAP ENSEMBLE FOR LEVEL B.....	2-27
2-9. DOFFING TAP ENSEMBLE FOR LEVEL C AND D.....	2-29
2-10. DECALS AND INSTRUCTION PLATES.....	2-29
Section III. OPERATION UNDER UNUSUAL CONDITIONS.....	2-30
2-11. WEAR TIME LIMITATIONS.....	2-30
2-12. DOFFING THE TAP ENSEMBLE IN A CHEMICAL ENVIRONMENT.....	2-30
2-13. EMERGENCY DOFFING OF THE TAP ENSEMBLE.....	2-30
CHAPTER 3. OPERATOR MAINTENANCE INSTRUCTIONS.....	3-1
Section I. OPERATOR MAINTENANCE PROCEDURES.....	3-1
3-1. INSPECTION.....	3-1
3-2. CLEANING.....	3-1
CHAPTER 4. UNIT MAINTENANCE INSTRUCTIONS.....	4-1
Section I. REPAIR PARTS, SPECIAL TOOLS, TEST, MEASUREMENT, AND DIAGNOSTIC EQUIPMENT (TMDE), AND SUPPORT EQUIPMENT.....	4-1
4-1. GENERAL.....	4-1
Section II. SERVICE UPON RECEIPT.....	4-1
4-2. SERVICE UPON RECEIPT OF MATERIEL.....	4-1
Section III. PREPARATION FOR STORAGE OR SHIPMENT.....	4-2
4-3. PREPARATION FOR STORAGE.....	4-2
4-4. PRESERVATION.....	4-2
4-5. PREPARATION FOR SHIPMENT.....	4-2
CHAPTER 5. DIRECT SUPPORT MAINTENANCE INSTRUCTIONS.....	5-1
Section I. REPAIR PARTS, SPECIAL TOOLS; TEST MEASUREMENT AND DIAGNOSTIC EQUIPMENT (TMDE) AND SUPPORT EQUIPMENT.....	5-1
5-1. COMMON TOOLS AND EQUIPMENT.....	5-1
5-2. SPECIAL TOOLS, TMDE, AND SUPPORT EQUIPMENT.....	5-1
5-3. REPAIR PARTS.....	5-2
Section II. DIRECT SUPPORT PREVENTIVE MAINTENANCE CHECKS AND SERVICES (PMCS).....	5-2
5-4. GENERAL.....	5-2

TABLE OF CONTENTS

	page
Section III. MAINTENANCE PROCEDURES	5-2
5-5. GENERAL	5-2
5-6. DECONTAMINATE	5-2
5-7. LAUNDERING THE M3 TAP/M40 TAP SPECIAL PURPOSE HOODS, M2A1 TAP BOOTS, M3 TAP COVERALLS, M1 TAP FOOTWEAR COVERS, M3/M4 TAP GLOVES, M2 TAP APRON	5-2
5-8. STITCHES, SEAMS AND STITCHING	5-2
5-9. PATCH REPAIRS IN BUTYL MATERIAL	5-4
5-10. REPAIR STRAPPING AND TUNNELS	5-7
5-11. REPLACE SNAP FASTENERS	5-10
5-12. M3 TAP AND M40 TAP SPECIAL PURPOSE HOODS	5-13
5-13. M2A1 TAP BOOTS	5-16
5-14. M3 TAP COVERALLS	5-18
5-15. M1 TAP FOOTWEAR COVERS	5-27
5-16. M3/M4 TAP GLOVES	5-28
5-17. M2 TAP APRON	5-30
5-18. LAUNDERING THE CHEMICAL PROTECTIVE CLOTHING OUTFIT	5-33
APPENDIX A. REFERENCES	A-1
APPENDIX B. MAINTENANCE ALLOCATION CHART	B-1
APPENDIX C. REPAIR PARTS AND SPECIAL TOOLS LIST (RPSTL)	C-1
APPENDIX D. COMPONENTS OF END ITEM AND BASIC ISSUE ITEMS LIST	D-1
APPENDIX E. ADDITIONAL AUTHORIZATION LIST	E-1
APPENDIX F. EXPENDABLE/DURABLE SUPPLIES AND MATERIALS LIST	F-1
APPENDIX G. ILLUSTRATED LIST OF MANUFACTURED ITEMS	G-1
GLOSSARY	GLOSSARY-1
ALPHABETICAL INDEX	Index 1

HOW TO USE THIS MANUAL

This manual, (TM 10-8415-210-13&P), contains general information, operating instructions, PMCS instructions, troubleshooting steps, and maintenance instructions for the Toxicological Agents Protective (TAP) Ensemble. Use the front cover index and thumb bleeds at the edge of the pages to quickly find the sections of the manual shown on the cover.



The manual has been divided into chapters, sections and paragraphs that are numbered in sequence. Pages, paragraphs, and illustrations are numbered by chapter. For example, chapter 2, page 3 is marked 2-3; chapter 3, paragraph 5 is marked 3-5; figure 2-3 is the third illustration in chapter 2. To quickly find specific information, use the table of contents. For example, the front cover index states that chapter 1 begins on page 1-1. The table of contents on page i tells you the exact page where the paragraph you want is located.

CHAPTER 1

INTRODUCTION

Subject	Page
Section I GENERAL INFORMATION	1-1
1-1 SCOPE.....	1-1
1-2 MAINTENANCE FORMS AND PROCEDURES.....	1-1
1-3 DESTRUCTION OF ARMY MATERIEL TO PREVENT ENEMY USE	1-1
1-4 PREPARATION FOR STORAGE OR SHIPMENT	1-1
1-5 QUALITY ASSURANCE (QA).....	1-1
1-6 NOMENCLATURE CROSS-REFERENCE LIST	1-1
1-7 REPORTING EQUIPMENT IMPROVEMENT RECOMMENDATIONS (EIR)...	1-2
1-8 CORROSION PREVENTION AND CONTROL	1-2
1-9 LIST OF ABBREVIATIONS	1-2
Section II EQUIPMENT DESCRIPTION.....	1-2
1-10 EQUIPMENT CHARACTERISTICS, CAPABILITIES, AND FEATURES	1-2
1-11 LOCATION AND DESCRIPTIONS OF MAJOR COMPONENTS	1-3
1-12 DIFFERENCES BETWEEN MODELS.....	1-5
1-13 EQUIPMENT CONFIGURATION.....	1-5
Section III PRINCIPLES OF OPERATION	1-5
1-14 CHEMICAL AND BIOLOGICAL PROTECTION	1-5

Section I. GENERAL INFORMATION

1-1. SCOPE. This manual describes Operator, Unit and Direct Support maintenance procedures for the Toxicological Agents Protective (TAP) Ensemble.

1-2. MAINTENANCE FORMS AND PROCEDURES. Department of the Army forms and procedures used for TAP maintenance shall be those prescribed by DA PAM 738-750 as contained in the Maintenance Management Update.

1-3. DESTRUCTION OF ARMY MATERIEL TO PREVENT ENEMY USE. Destruction of Army materiel to prevent enemy use shall be in accordance with TM 750-244-3.

1-4. PREPARATION FOR STORAGE OR SHIPMENT. Refer to paragraphs 4-3 and 4-5 for procedures to prepare TAP for storage or shipment.

1-5. QUALITY ASSURANCE (QA). TAP Ensemble components will be inspected in accordance with MIL-STD-105 at government acceptance to assure that Quality Assurance Standards are met.

1-6. NOMENCLATURE CROSS-REFERENCE LIST.

<u>Official Nomenclature:</u>	<u>Common Name:</u>
Clothing Outfit, Chemical Protect (Impregnated Set)	Clothing Outfit

1-7. REPORTING EQUIPMENT IMPROVEMENT RECOMMENDATIONS (EIR). If your TAP needs improvement, let us know. Send us an EIR. You, the user, are the only one who can tell us what you don't like about your equipment. Let us know why you don't like the design or performance. Put it on an SF 368 (Product Quality Deficiency Report). Mail it to us at: Commander, U.S. Army Aviation and Troop Command, ATTN: AMSAT-I-MDO, 4300 Goodfellow Blvd., St. Louis, MO 63120-1798. We will send you a reply.

1-8. CORROSION PREVENTION AND CONTROL.

a. Corrosion Prevention and Control (CPC) of Army materiel is a continuing concern. It is important that any corrosion problems with TAP be reported so that the problem can be corrected and improvements can be made to prevent the problem in future items.

b. While corrosion is typically associated with rusting of metals, it can also include deterioration of other materials, such as rubber and plastic. Unusual cracking, softening, swelling or breaking of these materials may be a corrosion problem.

c. If a corrosion problem is identified, it can be reported using SF 368, Quality Deficiency Report. Use of key words such as "corrosion", "rust", "deterioration", or "cracking" will assure that the information is identified as a CPC problem.

d. This form should be submitted to the address specified in DA Pam 738-750.

1-9. LIST OF ABBREVIATIONS.

CPC	Corrosion Prevention and Control
CTA	Common Table of Allowances
EIR	Equipment Improvement Recommendation
EOD	Explosive Ordnance Disposal
ESC	Equipment Serviceability Criteria
GB	Nonpersistent nerve agent
H	Blister agent
MWO	Modification Work Order
MTOE	Modified Table of Organizational Equipment
NBC	Nuclear, Biological, Chemical
STB	Supertropical Bleach
TMDE	Test, Measurement, and Diagnostic Equipment
TOE	Table of Organizational Equipment
U/M	Unit of Measure
UOC	Usable On Code
VX	Persistent nerve agent

Section II. EQUIPMENT DESCRIPTION

1-10. EQUIPMENT CHARACTERISTICS, CAPABILITIES, AND FEATURES.

a. Characteristics.

- Designed from impermeable rubber coated cloth material.
- Component maybe decontaminated for re-use.

b. Capabilities.

- Provide Chemical and Biological vapor and liquid agent protection.

1-10. EQUIPMENT CHARACTERISTICS, CAPABILITIES, AND FEATURES. (CONT)

c. Features.

- Can be utilized in a variety of configurations.
- Provide protection for different levels of contamination

1-11. **LOCATION AND DESCRIPTIONS OF MAJOR COMPONENTS.** The TAP Ensemble is not issued as a set; all components must be requisitioned separately. The TAP Ensemble consists of the following components, depicted in Figure 1-1:

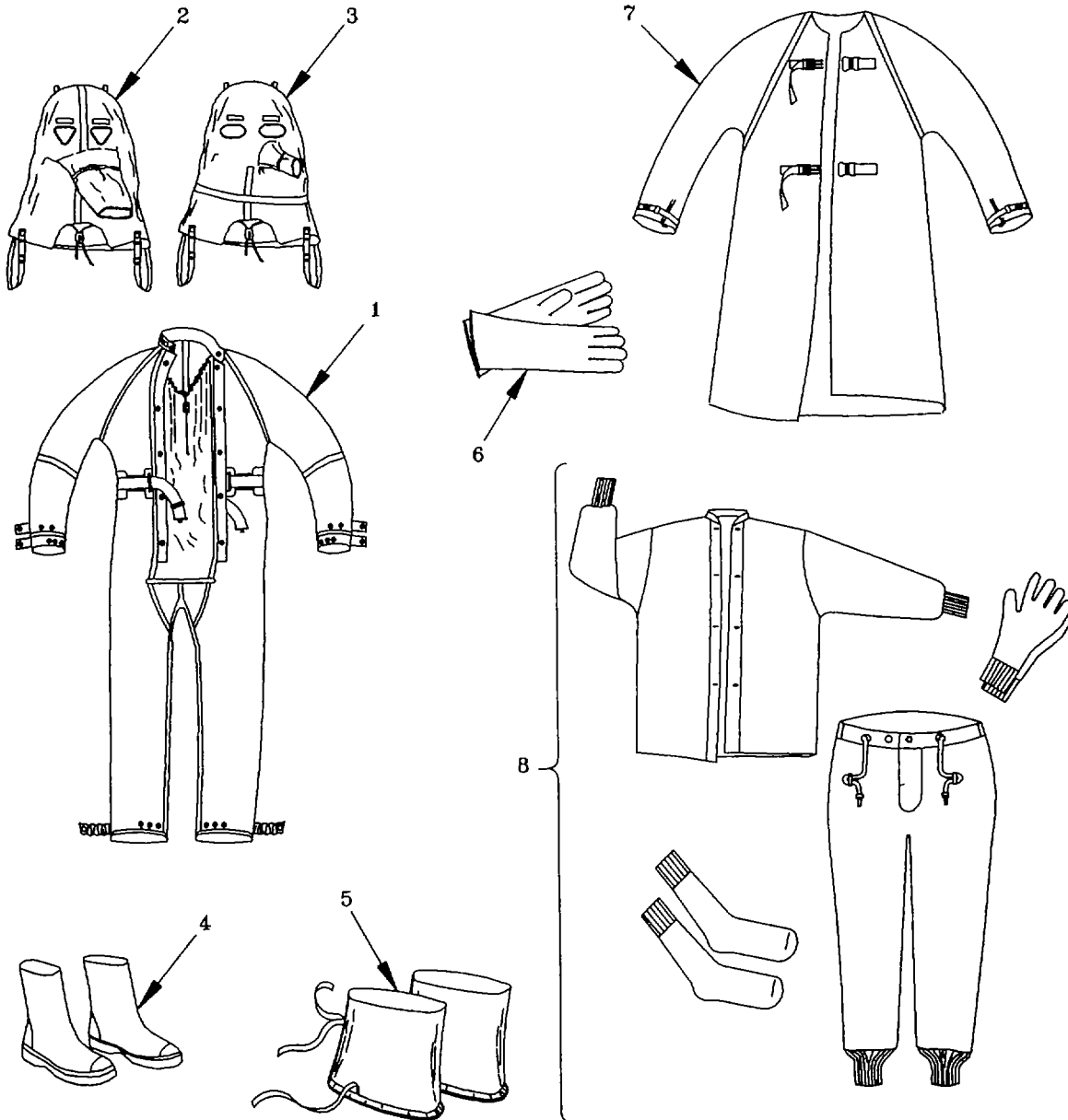


Figure 1-1. Major Components.
1-3

1-11. LOCATION AND DESCRIPTIONS OF MAJOR COMPONENTS. (CONT)

a. Toxicological Agents Protective Coveralls, M3 (1). The olive drab M3 TAP Coveralls (1) are made of butyl rubber-coated, nylon cloth. They have a gusset extending from collar to crotch, with an outer flap. Other features include an adjustable collar, double sleeve cuffs, trouser cuffs with elastic snap bands and an adjustable belt. When properly adjusted, the coveralls provide liquid agent protection for the portion of the body covered. The coveralls must be closed securely to be effective. The M3 TAP Coveralls are available in four sizes (small through extra-large.)

b. Toxicological Agents Protective Hoods (2) and (3). The M3 TAP Gas Mask Hood (2) is worn with the M9A1 Mask. Both the M3 TAP Gas Mask Hood and the M9A1 Mask will be replaced by the M40 TAP Special Purpose Mask Hood (3) and the M40 Special Purpose Mode Mask. The hoods and masks are not interchangeable.

(1) *Toxicological Agents Protective Gas Mask Hood, M3 (2)*. The M3 Toxicological Agents Protective Gas Mask Hood (2) is made of the same butyl rubber-coated fabric as the protective coveralls. It is designed for semipermanent mounting on the M9A1 Field Protective Mask. The hood has three adjustable openings with attached tie cords; two for the mask eyepieces and one large cover for the filtration canister. Butyl rubber-coated tape is cemented over the sewn seams to prevent leakage through needle holes. The lower portion of the hood is a two-layer shawl. The inner layer is placed inside the collar of the protective coveralls and the outer layer rests on the wearer's shoulders. The shawl of the hood is held in place by two adjustable straps, which are worn under the arms and secured in front by snap fasteners.

(2) *Toxicological Agents Protective Special Purpose Gas Mask Hood, M40 (3)*. The M40 TAP Special Purpose Gas Mask Hood (3) is made of the same butyl rubber-coated fabric as the protective coveralls. It is similar in design to the M3 TAP Gas Mask Hood. The M40 TAP Special Purpose Hood has a small canister cover located at the left cheek of the hood. The hood has three adjustable openings with attached tie cords for the mask eyepieces and canister. Butyl rubber coated tape is cemented over the sewn seams to prevent leakage through the needle holes. The lower portion of the hood is a two-layer shawl. The inner layer is placed inside the collar of the protective coveralls and the outer layer rests on the wearer's shoulders. The skirt of the hood is held in place by two adjustable straps, which are worn under the arms and secured in front by snap fasteners.

c. Toxicological Agents Protective Boots, M2A1 (4). The M2A1 TAP Boots, Type I (4) are made of butyl rubber, have a safety toe with a yellow overlay compound applied to the outside, have a hobnail tread design on the sole and heel, and are knee-length. The TAP M2A1 Boots are available in full sizes, 5 through 15.

d. Toxicological Agents Protective Footwear Covers, M1 (5). The M1 TAP Footwear Covers (5) are made of butyl rubber-coated, nylon cloth. The outer sole is made of alternating layers of cotton duck and butyl rubber. Tie tapes are located at the top and bottom of the covers. Left and right M1 TAP Footwear Covers are made to the same pattern and may be worn on either foot. The M1 TAP Footwear Covers are designed to protect the M2A1 Boots from gross contamination while also providing a rapid means of removing the contamination. M1 TAP Footwear Covers are available in size small, for shoe sizes up to 6-1/2; medium, for sizes 7 thru 11-1/2; and large, for sizes 12 and over.

e. Toxicological Agents Protective Gloves, M3/M4 (6). The M3/M4 TAP Gloves (6) are made of butyl rubber, which provides protection against vapors, aerosols, and small droplets of chemical agents. M3/M4 TAP Gloves have a rolled edge on the gauntlet. TAP Gloves are worn with the M3 TAP Coverall or the M2 TAP Apron and are worn over either surgical gloves or the Clothing Outfit gloves. M3/M4 TAP Gloves are available in five sizes (extra-small through extra-large).

1-11. LOCATION AND DESCRIPTIONS OF MAJOR COMPONENTS. (CONT)

f. Toxicological Agents Protective Apron, M2 (7). The M2 TAP Apron (7) is designed as a frock coat and is made of butyl coated cloth. The length of the coat, when worn, should extend below the top of the M2A1 TAP Boots. Webbing with buckles is used to close the back of the apron and the sleeve cuffs. TAP Apron is available in five sizes (extra-small through extra-large).

g. Chemical Protective Clothing Outfit (Impregnated Set) (8). The Chemical Protective Clothing Outfit (8) consists of a shirt, a trouser liner, gloves, 3 pairs of socks, and a clothing bag. The basic material is a cotton sateen cloth with a minimum absorption rate of 60 per cent. Both the shirt and trousers have cuff tubing made from seamless, 1 rib knit cotton. The Clothing Outfit is designed to protect the wearer from small liquid droplets and vapors of blister agents when worn underneath outerwear. Chemical Protective Clothing Outfit is available in five sizes (extra-small through extra-large).

1-12. DIFFERENCES BETWEEN MODELS. The M3 TAP and M40 TAP Special Purpose Gas Mask Hoods, worn with the M9A1 Field Mask and M40 Special Purpose Mode Masks respectively are similar in construction, differing only in the location and size of the filtration canister covers on each. The M3 TAP Gas Mask Hood has one large filtration canister cover located near the center of the hood for use with the M9A1 Field Mask. The M40 TAP Special Purpose Gas Mask Hood has one small canister cover for use with the M40 Special Purpose Mode Mask. Hoods are not interchangeable with the two mask types.

1-13. EQUIPMENT CONFIGURATION. The TAP Ensemble components are worn in combinations appropriate to the threat level. Refer to DA PAM 385-61 for the TAP ensemble components required for various threat levels.

Section III. PRINCIPLES OF OPERATION

1-14. CHEMICAL AND BIOLOGICAL PROTECTION. The TAP Ensemble is a multi-level impermeable outfit designed to provide protection against airborne and liquid chemical agents. Impermeable clothing is designed to prevent the passage of air and moisture through the fabric. Although resistant to liquid chemicals, penetration may occur after prolonged exposure. Liquid chemicals should therefore be neutralized or removed as quickly as possible. The TAP Ensemble is designed to be used primarily by Explosive Ordnance Disposal (EOD) and Depot level personnel engaged in hazardous decontamination or other special operations where the splashing of liquid chemical agents may occur.

1-5/(1-6 blank)

CHAPTER 2

OPERATING INSTRUCTIONS

Subject	Page
Section I	PREVENTIVE MAINTENANCE CHECKS AND SERVICES (PMCS) 2-1
2-1	INTRODUCTION TO PMCS TABLE 2-1
Section II	OPERATION UNDER USUAL CONDITIONS 2-16
2-2	ASSEMBLY AND PREPARATION FOR USE 2-16
2-3	LEVELS OF PROTECTION AND APPLICABILITY OF TAP ENSEMBLE COMPONENTS..... 2-16
2-4	DONNING TAP ENSEMBLE FOR LEVEL A..... 2-17
2-5	DONNING TAP ENSEMBLE FOR LEVEL B..... 2-21
2-6	DONNING TAP ENSEMBLE FOR LEVEL C AND D..... 2-23
2-7	DOFFING TAP ENSEMBLE FOR LEVEL A..... 2-24
2-8	DOFFING TAP ENSEMBLE FOR LEVEL B..... 2-27
2-9	DOFFING TAP ENSEMBLE FOR LEVEL C AND D..... 2-29
2-10	DECALS AND INSTRUCTION PLATES 2-29
Section III	OPERATION UNDER UNUSUAL CONDITIONS 2-30
2-11	WEAR TIME LIMITATIONS..... 2-30
2-12	DOFFING THE TAP ENSEMBLE IN A CHEMICAL ENVIRONMENT 2-30
2-13	EMERGENCY DOFFING OF THE TAP ENSEMBLE..... 2-30

Section I. PREVENTIVE MAINTENANCE CHECKS AND SERVICES (PMCS)

2-1. INTRODUCTION TO PMCS TABLE. The TAP Ensemble components must be inspected regularly to find, correct and prevent defects. Record all defects found during the performance of PMCS and the steps taken to correct them on a DA Form 2404, Equipment Inspection and Maintenance Worksheet, or in accordance with local SOP. Instructions for reporting/correcting noted deficiencies are contained in DA Pam 738-750.

a. General. Table 2-1 (PMCS Table) has been provided so you can maintain your equipment in good operating condition and keep it ready for its primary mission.

b. Warnings and Cautions. Always observe the WARNINGS and CAUTIONS appearing in your PMCS table. WARNINGS and CAUTIONS appear before applicable procedures. You must observe these WARNINGS and CAUTIONS to prevent serious injury to yourself or others and prevent your equipment from being damaged.

c. Explanation of Table Entries.

(1) Item No. Column. Numbers in this column are for reference. When completing DA Form 2404 (Equipment Inspection and Maintenance Worksheet), include the item number for the check/service indicating a fault. Item numbers also appear in the order that you must do your checks and services for the intervals listed.

2-1. INTRODUCTION TO PMCS TABLE. (CONT)

(2) *Interval Column.* This column tells you when you must do the procedure in the procedure column. The **BEFORE** procedures must be done before you operate or use the equipment for its intended mission. **DURING** procedures must be done during the time you are operating or using the equipment for its intended mission. **AFTER** procedures must be done immediately after you have operated or used the equipment. **QUARTERLY** procedures must be done every 90 days after issue.

(3) *Location - Item to Check/Service Column.* This column describes the location and the item to be checked or serviced.

(4) *Procedure Column.* This column gives the procedure you must follow to check or service the item listed in the Check/Service column to know if the equipment is ready or available for its intended mission or for operation. You must perform the procedure at the time specified in the interval column.

(5) *Not Fully Mission Capable If: Column.* Information in this column tells you what faults will keep your equipment from being capable of performing its primary mission. If you perform check and service procedures that show faults listed in this column, do not operate the equipment. Follow standing operating procedures for maintaining the equipment or reporting equipment failure.

CAUTION

**Remove all jewelry and long finger nails prior to handling TAP Ensemble components.
Failure to do so may result in damage to TAP Ensemble components.**

- d. Mark all suspected defects found during PMCS with chalk (Appendix F, item 1).

Table 2-1. Preventive Maintenance Checks and Services for TAP Ensemble

Item No.	Interval	Location	Procedure	Not Fully Mission Capable If:
		Item to Check/Service		
1	Before	M8 TAP Hood and M40 TAP Special Purpose Hood	<p>Inspect fabric for holes, cuts, tears, pits, blisters, tunnels, delamination or exposed base fabric.</p> <p>Inspect strapping for exposed stitching, blistering, tunnels, or detachments from hood.</p> <p>Check all fasteners and shoulder straps for any damage</p> <p>Check that inspection due date stencilled on hood has not passed</p>	<p>Fabric has holes, cuts, tears, pits, blisters, tunnels, delamination, or exposed base fabric.</p> <p>Strapping has exposed stitching, blistering, tunnels, or detachments from hood.</p> <p>Fasteners and shoulder straps do not permit proper closure and adjustment.</p> <p>Inspection due date has passed.</p>

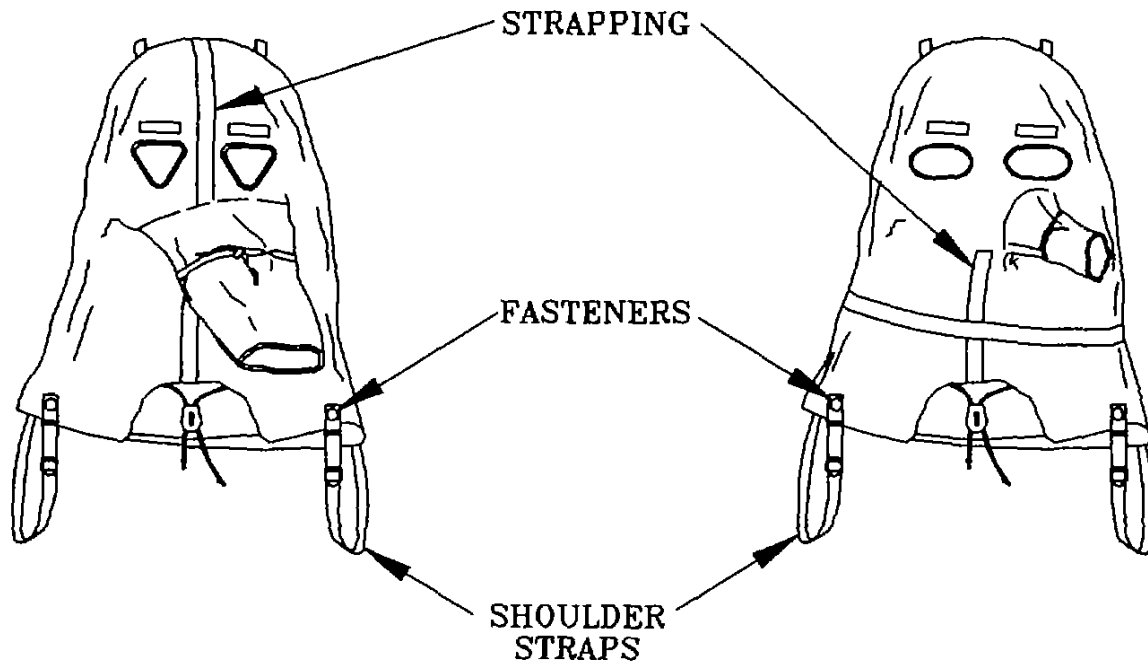


Table 2-1. Preventive Maintenance Checks and Services for TAP Ensemble (Cont)

Item No.	Interval	Location	Procedure	Not Fully Mission Capable If:
		Item to Check/Service		
2	Before	M2A1 TAP Boots	Inspect boots for holes, cuts, tears, cracking, dry rot or tackiness. Inspect seams for dry rot. Check that inspection due date stencilled on boots has not passed.	Boots have any holes, cuts, tears, cracking, tackiness or dry rot in seams. Inspection due date has passed.

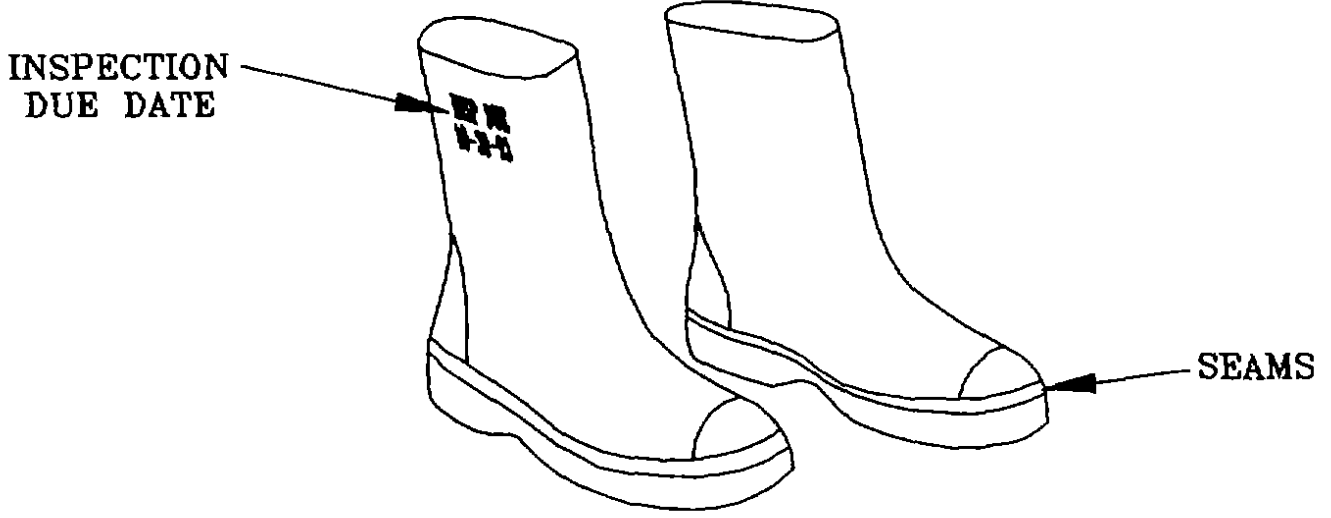


Table 2-1. Preventive Maintenance Checks and Services for TAP Ensemble (Cont)

Item No.	Interval	Location	Procedure	Not Fully Mission Capable If:
		Item to Check/Service		
3	Before	M3 TAP Coveralls	<p>Inspect snap fasteners to determine if they close securely and open freely. Determine if any are missing, reversed or improperly attached.</p> <p>Inspect neck adjustment straps for proper attachment.</p> <p>Inspect strapping for blistering, tunnels, exposed stitching or detachment from fabric.</p> <p>Inspect material for cuts, holes, tears, pits, blisters, tunnels, cloth delamination or exposed base fabric</p> <p>Ensure suspenders are present and secure.</p> <p>Check that inspection due date stencilled on coveralls has not passed.</p>	<p>Snap fasteners are missing or do not operate properly.</p> <p>Neck adjustment straps are not properly secured</p> <p>Strapping has blisters, tunnels, exposed stitching or is not properly attached.</p> <p>Material has cuts, holes, tears, pits, blisters, tunnels or delaminations.</p> <p>Inspection due date has passed</p>

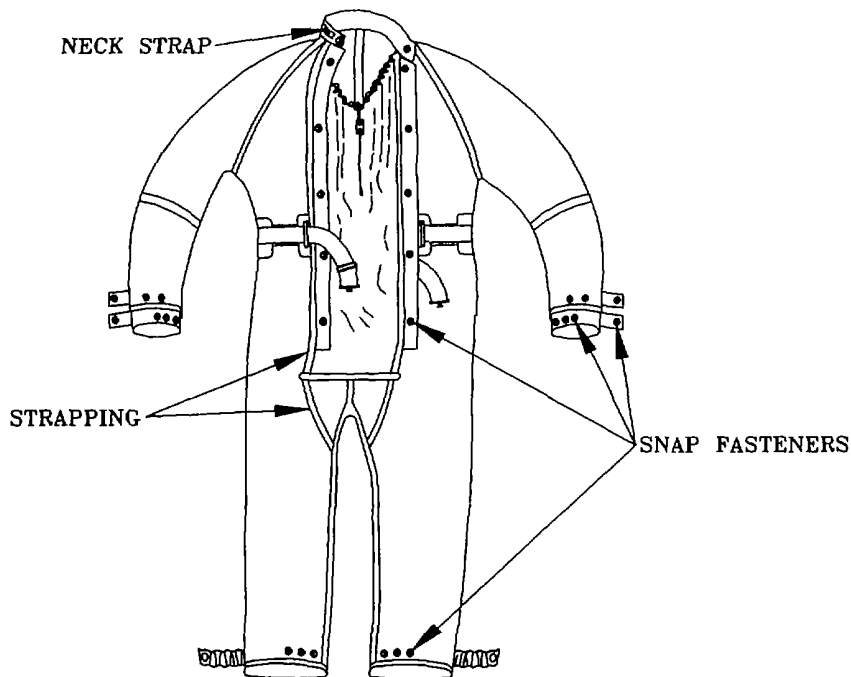


Table 2-1. Preventive Maintenance Checks and Services for TAP Ensemble (Cont)

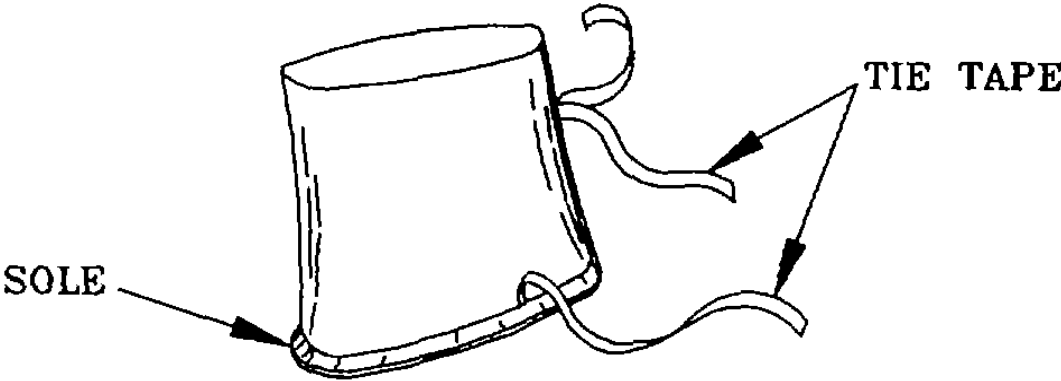
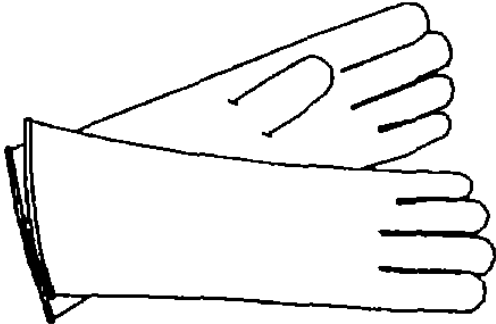
Item No.	Interval	Location	Procedure	Not Fully Mission Capable If:
		Item to Check/Service		
4	Before	M1 TAP Footwear Covers	<p>Inspect fabric for cuts, holes, tears, pits, blisters, tunnels, cloth delamination or exposed base fabric.</p> <p>Inspect soles for holes.</p> <p>Inspect tie tapes for dry rot, exposed stitching, fraying, and blistering at attachment point.</p> <p>Check that inspection due date stencilled on footwear covers has not passed.</p>	<p>Item has cuts, holes, tears, pits, blisters, tunnels, delamination or exposed base fabric.</p> <p>Inspection due date has passed.</p>
				
5	Before	M3/M4 TAP Gloves	<p>Inspect butyl gloves for holes, cuts, tears, cracking, dry rot or tackiness. Check that inspection due date stencilled on gloves has not passed.</p>	<p>Gloves have any holes, cuts, tears, cracking, dry rot or tackiness. Inspection due date has passed.</p>
				

Table 2-1. Preventive Maintenance Checks and Services for TAP Ensemble (Cont)

Item No.	Interval	Location	Procedure	Not Fully Mission Capable If:
		Item to Check/Service		
6	Before	M2 TAP Apron	<p>Inspect strapping for open seams or tunnels</p> <p>Check fabric for holes, tears, cuts, pits, blisters, tunnels, delamination or exposed base fabric.</p> <p>Inspect for missing, broken, bent or cracked buckles.</p> <p>Inspect wrist adjustment buckles for misrouted straps.</p> <p>Inspect tapes for dry rot, exposed stitching, blistering at attachment point</p> <p>Check that inspection due date stenciled on apron has not passed.</p>	<p>Strapping has opened seams or tunnels.</p> <p>Material has cuts, holes, tears, pits, blisters, tunnels or delamination.</p> <p>Buckles are broken or missing, tapes have dry rot or blistering at attachment points.</p> <p>Inspection due date has passed.</p>

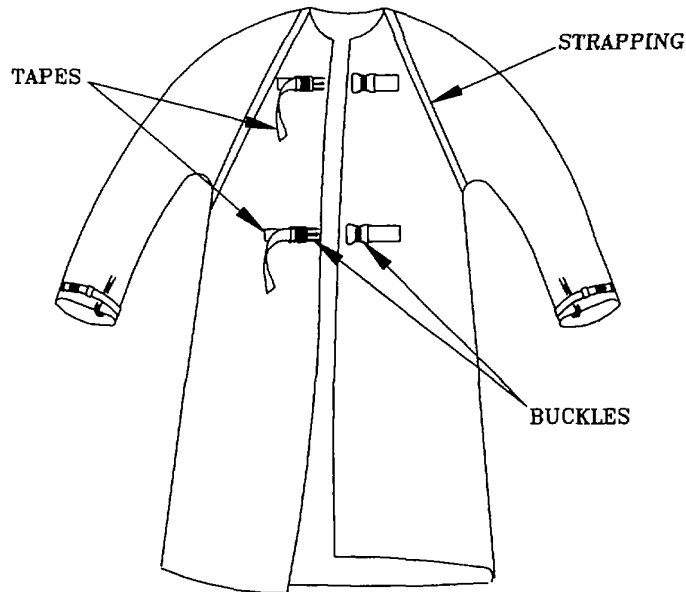


Table 2-1. Preventive Maintenance Checks and Services for TAP Ensemble (Cont)

Item No.	Interval	Location	Procedure	Not Fully Mission Capable If:
		Item to Check/Service		
7	Before	Clothing Outfit	<p>Check clothing outfit items for any rips, tears, or holes. Check all fasteners and closures for any damage.</p> <p>Ensure item has not been laundered more than six times or worn more than seven times without being reimpregnated with certainty.</p>	<p>Item has a rip, tear, or hole of any size. Fasteners or closures do not permit proper fit.</p> <p>Clothing outfit item has been laundered more than 6 times, worn more than 7 times, or number of laundering or wearings can not be determined</p>

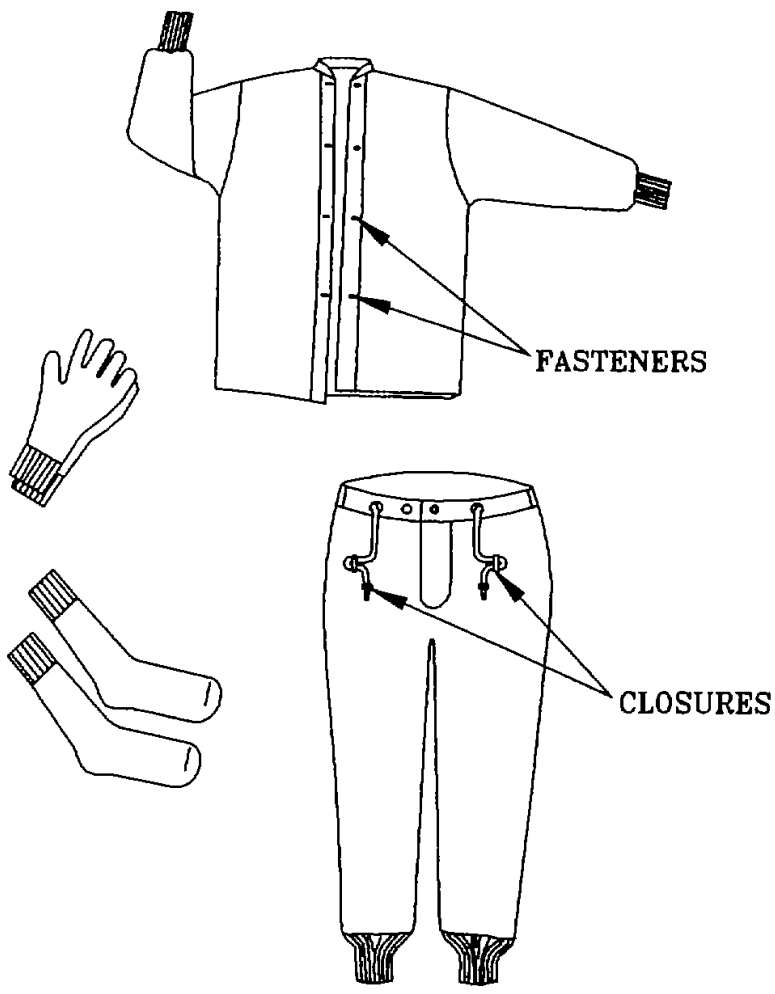


Table 2-1. Preventive Maintenance Checks and Services for TAP Ensemble (Cont)

Item No.	Interval	Location	Procedure	Not Fully Mission Capable If:
		Item to Check/Service		
8	After	M3 TAP Hood and M40 TAP Special Purpose Hood	<p>Inspect fabric for holes, cuts, tears, pits, blisters, tunnels, delamination or exposed base fabric.</p> <p>Inspect strapping for exposed stitching, blistering, tunnels, or detachments from hood.</p> <p>Check all fasteners and shoulder straps for any damage.</p> <p>Check that inspection due date stenciled on hood has not passed.</p>	<p>Fabric has holes, cuts, tears, pits, blisters, tunnels, delamination, or exposed base fabric.</p> <p>Strapping exposed stitching, blistering, tunnels, or detachments from hood.</p> <p>Fasteners and shoulder straps do not permit proper closure and adjustment</p> <p>Inspection due date has passed.</p>

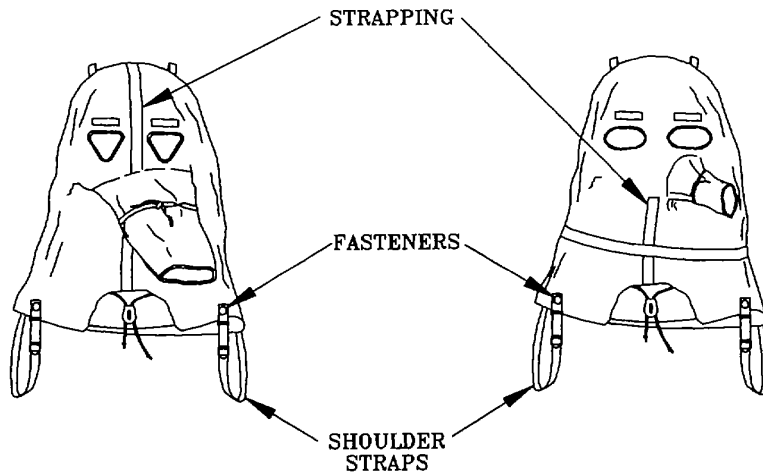


Table 2-1. Preventive Maintenance Checks and Services for TAP Ensemble (Cont)

Item No.	Interval	Location	Procedure	Not Fully Mission Capable If:
		Item to Check/Service		
	After	2A1 TAP Boots	<p>Inspect boots for holes, cuts, tears, cracking, dry rot or tackiness. Inspect seams for dry rot.</p> <p>Check that inspection due date stenciled on boots has not passed.</p>	<p>Boots have any holes, cuts, tears, cracking, tackiness or dry rot in seams.</p> <p>Inspection due date has passed.</p>

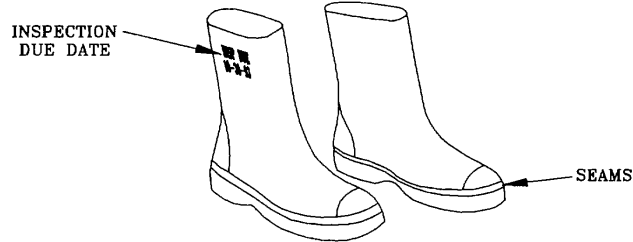


Table 2-1. Preventive Maintenance Checks and Services for TAP Ensemble (Cont)

Item No.	Interval	Location	Procedure	Not Fully Mission Capable If:
		Item to Check/Service		
10	After	M3 TAP Coveralls	<p>Inspect snap fasteners to determine if they close securely and open freely. Determine if any are missing, reversed or improperly attached.</p> <p>Inspect neck adjustment straps for proper attachment</p> <p>Inspect strapping for blistering, tunnels, exposed stitching or detachment from fabric.</p> <p>Inspect material for cuts, holes, tears, pits, blisters, tunnels, cloth delaminations or exposed base fabric.</p> <p>Ensure suspenders are present and secure.</p> <p>Check that inspection due date stenciled on coveralls has not passed.</p>	<p>Snap fasteners are missing or do not operate properly.</p> <p>Neck adjustment straps are not properly secured.</p> <p>Strapping has blisters, tunnels, exposed stitching or is not properly attached.</p> <p>Material has cuts, holes, tears, pits, blisters, tunnels or delaminations</p> <p>Inspection due date has passed.</p>

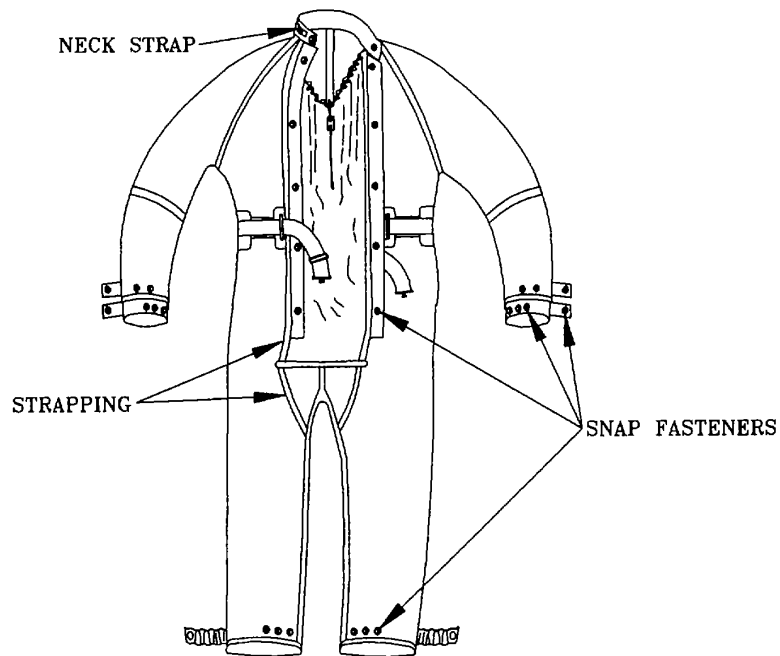


Table 2-1. Preventive Maintenance Checks and Services for TAP Ensemble (Cont)

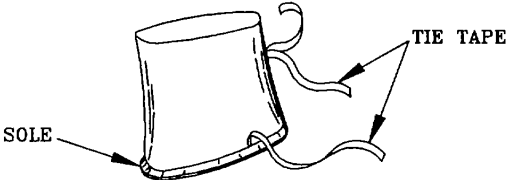
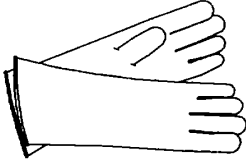
Item No.	Interval	Location	Procedure	Not Fully Mission Capable If:
		Item to Check/Service		
11	After Footwear Covers	M1 TAP	<p>Inspect fabric for cuts, holes, tears, pits, blisters, tunnels, cloth delamination or exposed base fabric. Inspect soles for holes. Inspect tie tapes for dry rot, exposed stitching, fraying, and blistering at attachment point. Check that inspection due date stenciled on footwear covers has not passed.</p> 	<p>Item has cuts, holes, tears, pits, blisters, tunnels, delamination or exposed base fabric.</p> <p>Inspection due date has passed.</p>
12	After	M3/M4 TAP Gloves	<p>Inspect butyl gloves for holes, cuts, tears, cracking, dry rot or tackiness. Check that inspection due date stenciled on gloves has not passed.</p> 	<p>Gloves have any holes, cuts, tears, cracking, dry rot or tackiness. Inspection due date has passed.</p>

Table 2-1. Preventive Maintenance Checks and Services for TAP Ensemble (Cont)

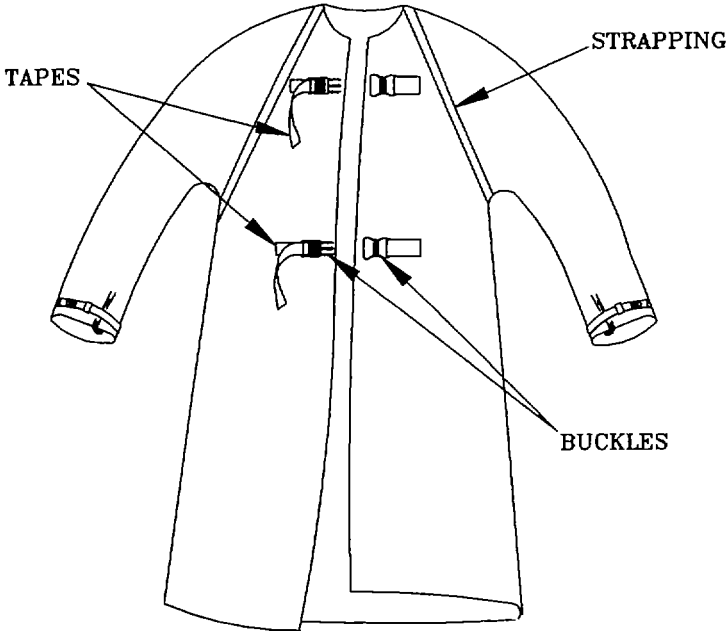
Item No.	Interval	Location	Procedure	Not Fully Mission Capable If:
		Item to Check/Service		
13	After	M2 TAP Apron	<p>Inspect strapping for open seams or tunnels.</p> <p>Check fabric for holes, tears, cuts, pits, blisters, tunnels, delamination or exposed base fabric.</p> <p>Inspect for missing, broken, bent or cracked buckles</p> <p>Inspect wrist adjustment buckles for misrouted straps</p> <p>Inspect tapes for dry rot, exposed stitching, blistering at attachment point.</p> <p>Check that inspection due date stenciled on apron has not passed.</p>	<p>Strapping has opened seams or Tunnels.</p> <p>Material has cuts, holes, tears, pits, blisters, tunnels or delamination.</p> <p>Buckles are broken or missing, tapes have dry rot or blistering at attachment points.</p> <p>Inspection due date has passed.</p>
 <p>The diagram shows a front view of an M2 TAP Apron. It features a central front opening with two rows of buckles. There are two large straps on the sides, each with a buckle at the top and a wrist adjustment buckle at the bottom. The apron has a high collar and a hemmed bottom. Labels with arrows point to 'TAPES' on the side straps, 'STRAPPING' on the top shoulder straps, and 'BUCKLES' on the front and wrist adjustment buckles.</p>				

Table 2-1. Preventive Maintenance Checks and Services for TAP Ensemble (Cont)

Item No.	Interval	Location	Procedure	Not Fully Mission Capable If:
		Item to Check/Service		
14	After	Clothing Outfit	<p>Check clothing outfit items for any rips, tears, or holes. Check all fasteners and closures for any damage</p> <p>Ensure item has not been laundered more than six times or worn more than seven times without being reimpregnated. with certainty.</p>	<p>Item has a rip, tear, or hole of any size. Fasteners or closures do not permit proper fit.</p> <p>Clothing outfit item has been laundered more than 6 times, worn more than 7 times, or number of launderings or wearings can not be determined</p>

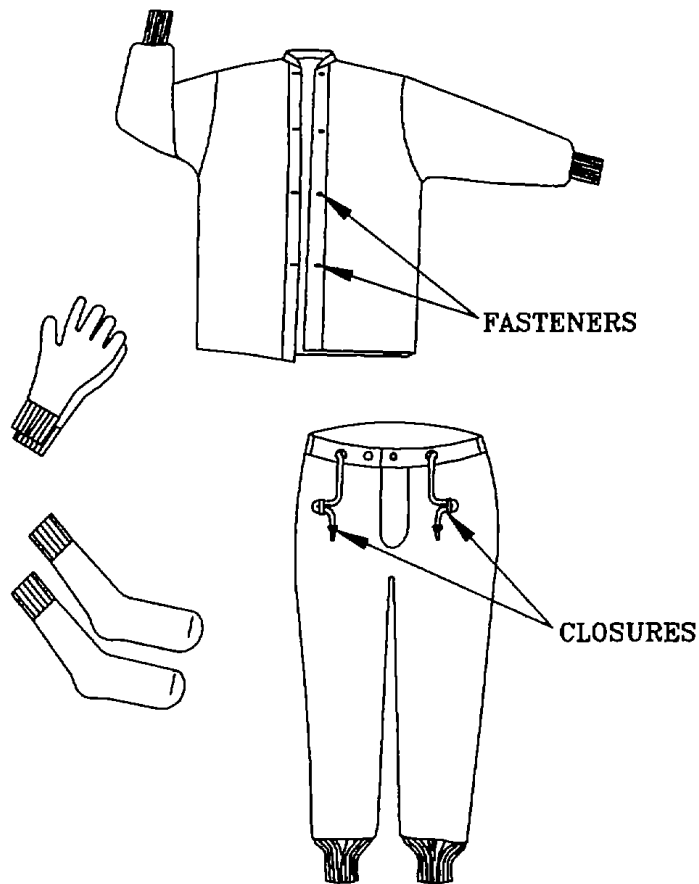
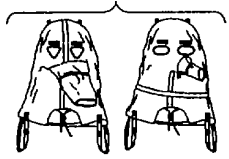



Table 2-1. Preventive Maintenance Checks and Services for TAP Ensemble (Cont)

Item No.	Interval	Location	Procedure	Not Fully Mission Capable If:
		Item to Check/Service		
15	Quarterly	MS TAP Hood; M40 TAP Special Purpose Hood; M2A1 TAP Boots; M3 TAP Coveralls, M1 TAP Footwear Covers, M3/M4 Tap Gloves, M2 TAP Apron, Clothing Outfit	Turn m for inspection and testing	Item has not been inspected by direct support in the last 90 days.


HOODS



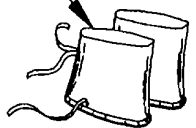
GLOVES



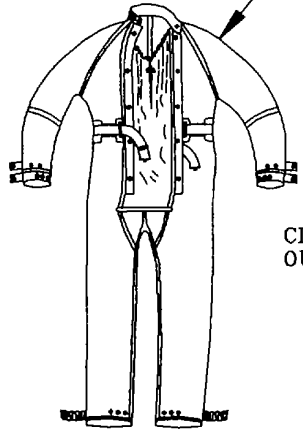
BOOTS



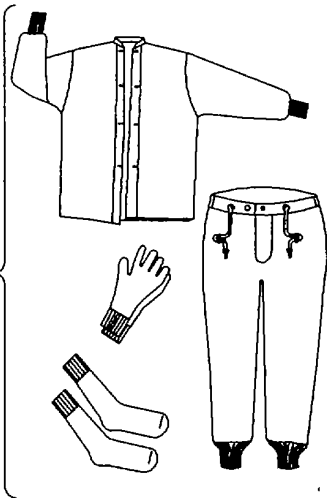
FOOTWEAR COVERS



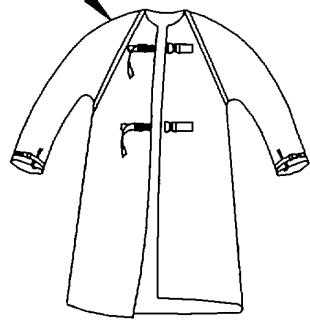
COVERALLS



CLOTHING OUTFIT



APRON

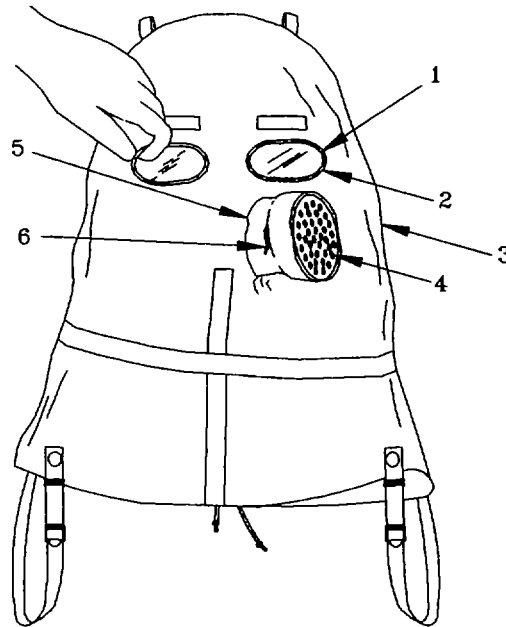


Section II. OPERATION UNDER USUAL CONDITIONS

CAUTION

Remove all jewelry and long finger nails prior to handling TAP Ensemble components. Failure to do so may result in damage to TAP Ensemble components.

2-2. ASSEMBLY AND PREPARATION FOR USE. Before donning the TAP Ensemble, fit and mount the M3 TAP Hood on the M9A1 Mask, or mount the M40 TAP Special Purpose Hood on the M40 Mask.



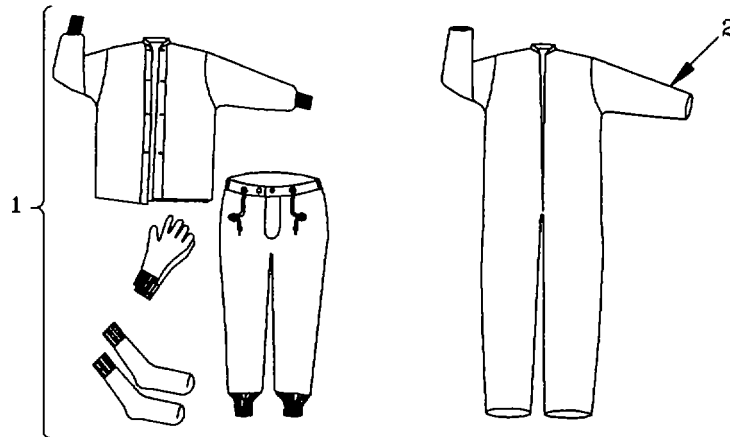
- a. Line up the lenses (1) with the openings (2) in the hood (3).
- b. Start at the center of the mask, between the lenses (1) and stretch the lens openings (2) one at a time, over the mask lenses (1).
- c. Insert canister (4) into snout (5) of hood (3) until drawstring (6) can be tied behind the canister (4).
- d. Turn hood inside-out and tie drawstrings around lenses.

2-3. LEVELS OF PROTECTION AND APPLICABILITY OF TAP ENSEMBLE COMPONENTS. TAP Ensemble components are worn in combinations appropriate to the threat level. Refer to DA PAM 385-61 for TAP ensemble components required for various levels of protection.

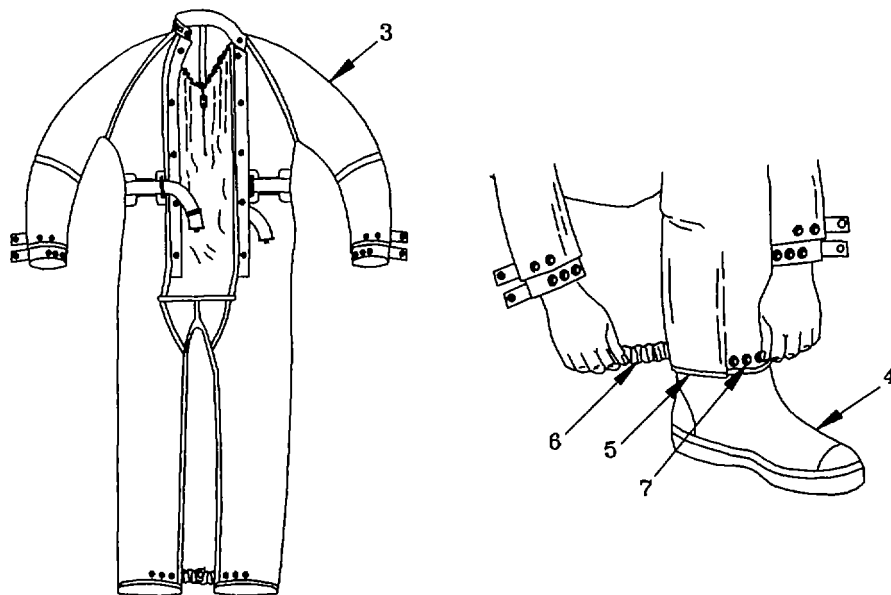
2-4. DONNING TAP ENSEMBLE FOR LEVEL A.

NOTE

Assistance is required to don TAP Ensemble.



- a. Don the Clothing Outfit (1), BDUs or cloth coveralls (2), as required by paragraph 2-3.
- b. Initially Donning M3 TAP Coveralls.



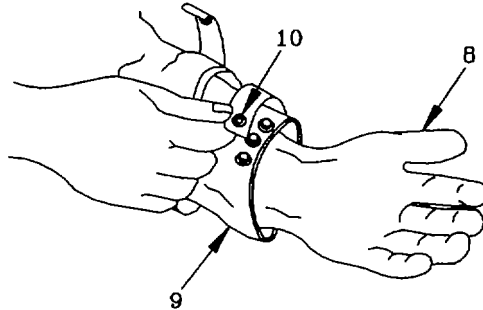
- (1) Don M2A1 TAP boots (4).
- (2) Don M3 TAP Coveralls (3), leaving all closures open.
- (3) Pull the trouser cuffs (5) down over boots (4). Gather trouser cuffs (5) under elastic closure strap (6), and fasten trouser cuff snap fasteners (7).

2-4. DONNING TAP ENSEMBLE FOR LEVEL A. (CONT)

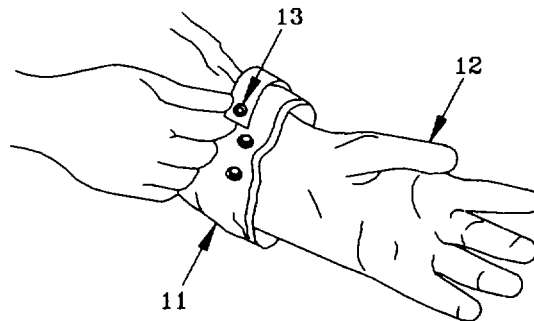
c. Donning Gloves.

NOTE

Talcum powder sprinkled inside the M3/M4 TAP gloves will reduce friction while donning.

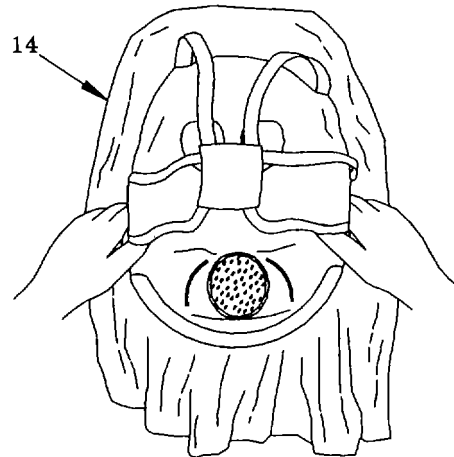


- (1) Don surgeon's gloves (8) if required by paragraph 2-3.
- (2) Tuck the cuff of inner glove (8) (surgeon's or clothing outfit) under coverall inner sleeve cuff (9). Adjust sleeve for a comfortable, tight closure over the inner gloves (8) and fasten the sleeve cuff snap fasteners (10).

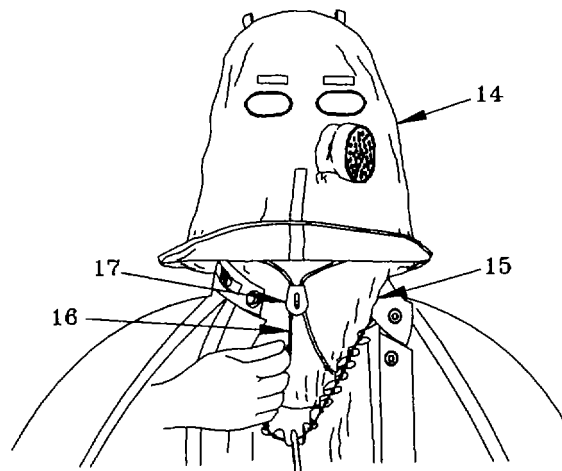


- (3) Pull back coverall outer sleeve cuffs (11) and don outer M3/M4 TAP gloves (12), pulling them up to cover coverall inner cuffs (9).
- (4) Pull outer sleeve cuffs (11) down to cover M3/M4 TAP Gloves (12). Fasten outer sleeve cuff snap fasteners (13).

d. Donning M3 TAP Hood and M9A1 Mask or M40 TAP Special Purpose Hood and M40 Mask.



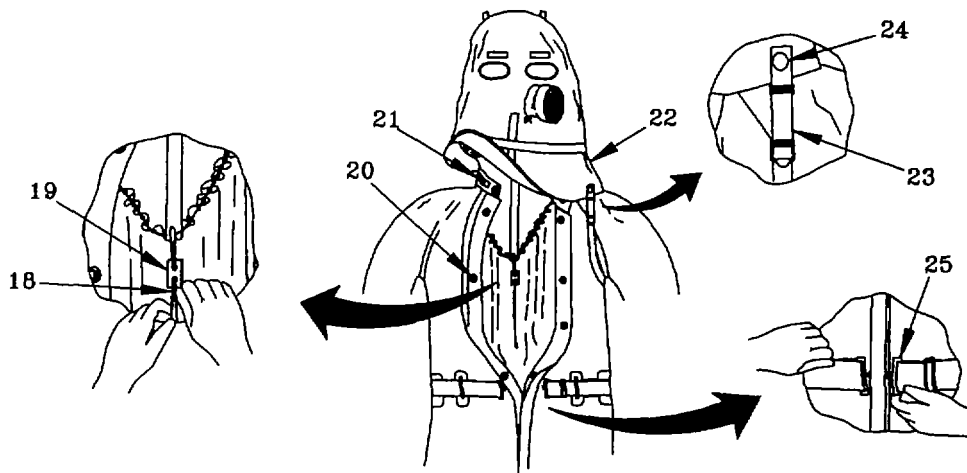
- (1) Pull hood (14) forward over the mask, turning the hood (14) inside out.
- (2) Don mask and make necessary adjustments to the head harness IAW TM 3- 4240-204-14 or TM 3-4240-300-10-1.



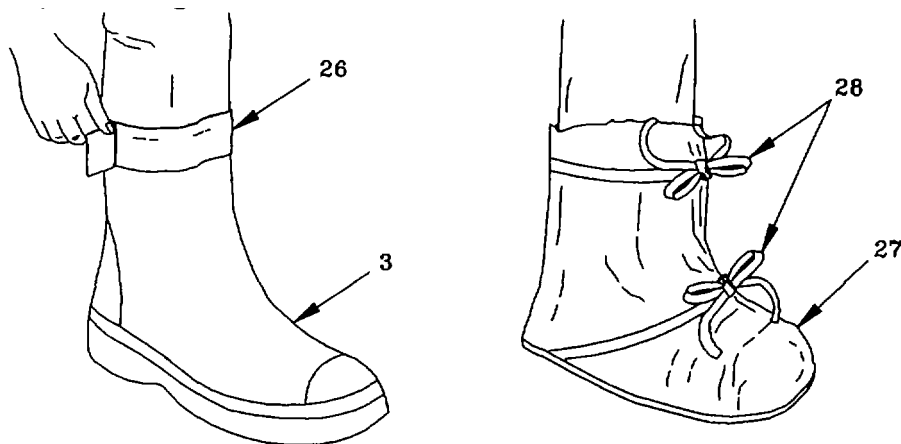
- (3) Flip hood (14) over the head and tuck hood inner skirt (15) under the coverall collar and gusset. Pull hood drawcord (16) snug and secure with cord lock (17).

2-4. DONNING TAP ENSEMBLE FOR LEVEL A. (CONT)

e. Donning the M3 TAP Coveralls.

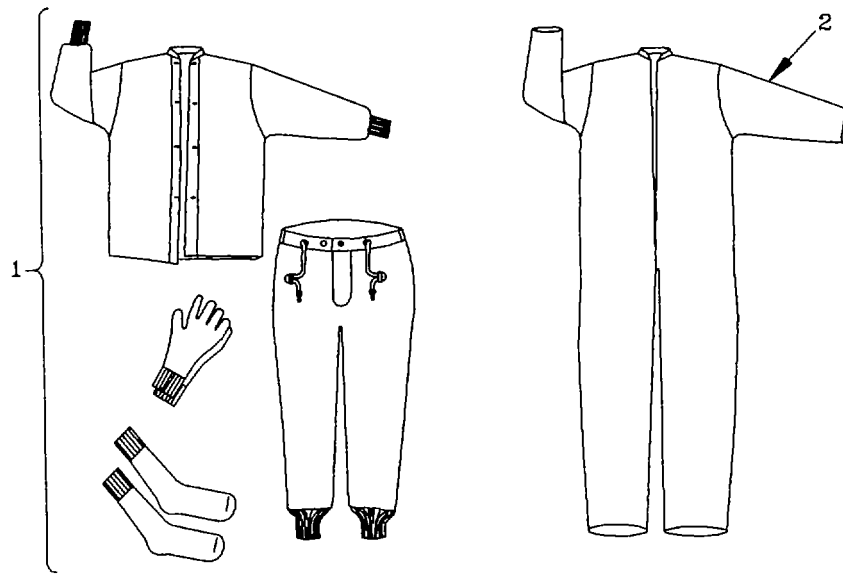


- (1) Draw coverall gusset snug with drawcord (18) and secure with cord lock (19). Fasten all snap fasteners (20) and tighten neck straps (21).
- (2) Drop hood outer skirt (22) over the shoulders and secure by passing the shoulder straps (23) under the arms, attaching them to the front snap fasteners (24).
- (3) Adjust and tighten belt (25).

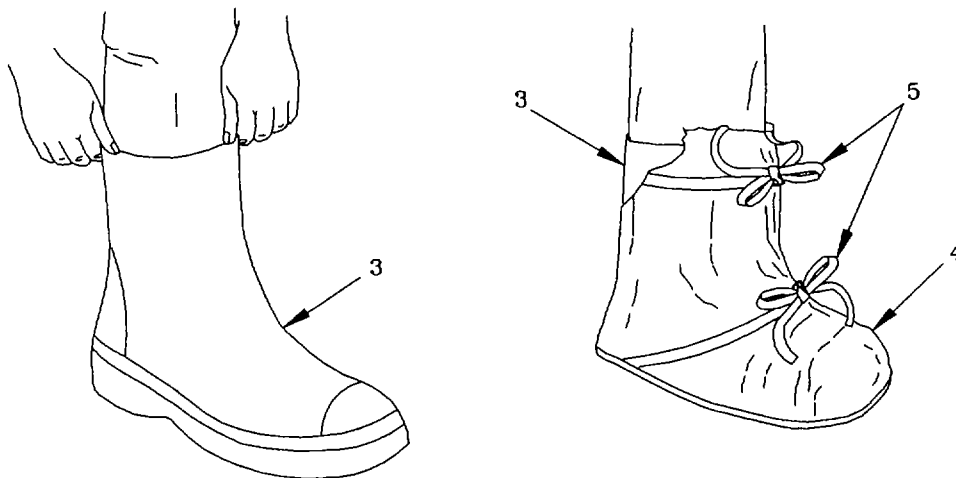


- (4) Seal cuffs and ankles with at least one complete wrap of tape (26) (Appendix F, Item 2), leaving a tab of about an inch to allow easy removal with gloved hand.
- f. Donning M1 TAP Footwear Covers (Optional). Don M1 TAP Footwear Covers (27) over M2A1 TAP Boots (3). Fasten footwear cover (27) over each trouser leg with cotton tie tapes (28). Tuck in loose ends to prevent them from catching on anything.

2-5. DONNING TAP ENSEMBLE FOR LEVEL B.



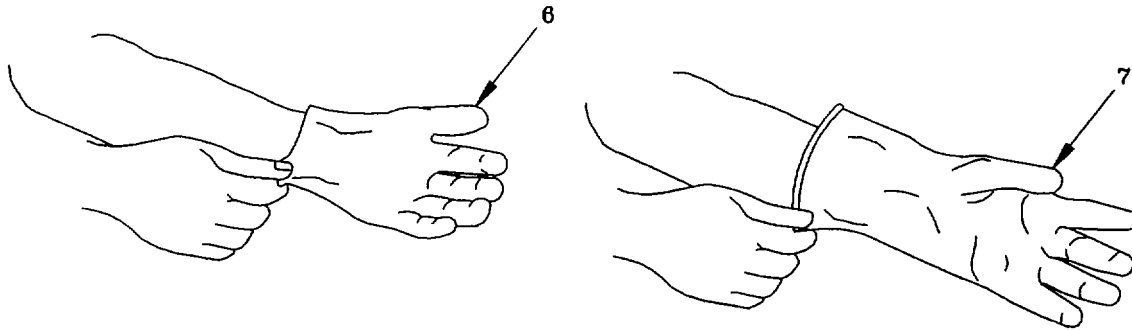
- a. Don Clothing Outfit (1), BDUs or cloth coveralls (2), as required by paragraph 2-3.



- b. Don M2A1 TAP Boots (3).
- c. Donning M1 TAP Footwear Covers (Optional). Don M1 TAP Footwear Covers (4) over the M2A1 TAP boots (3). Fasten cover (4) over each trouser leg with cotton tie tapes (5). Tuck in loose ends to prevent them from catching on anything.

2-5. DONNING TAP ENSEMBLE FOR LEVEL B. (CONT)

d. Donning Gloves.



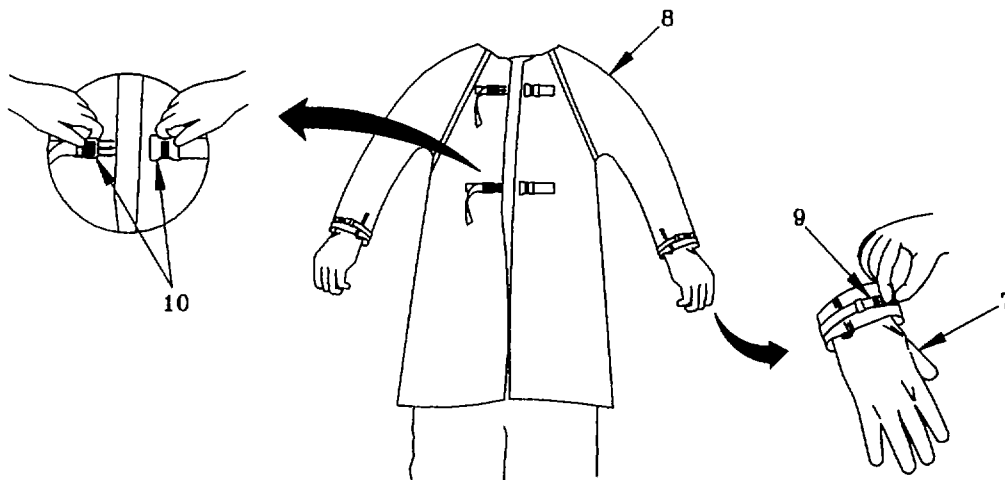
- (1) Don surgeon's gloves (6) if required by paragraph 2-3.

NOTE

Talcum powder sprinkled inside the M3/M4 TAP gloves will reduce friction while donning.

- (2) Don M3/M4 TAP gloves (7), pulling them up to completely cover inner gloves (6).

e. Donning M2 TAP Apron.

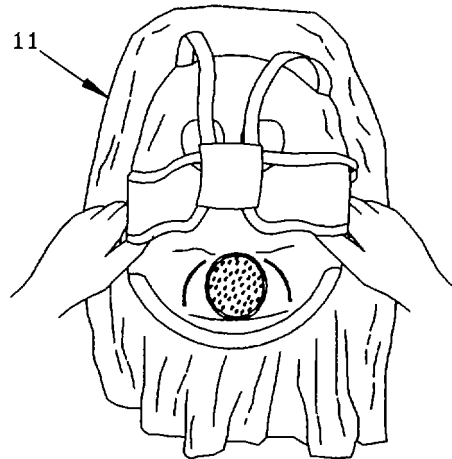


- (1) Don M2 TAP Apron (8).
- (2) Adjust wrist straps (9) to maintain a comfortable but snug fit, ensuring M3 TAP gloves (7) remain inside the apron sleeves.
- (3) Have buddy secure back straps (10).

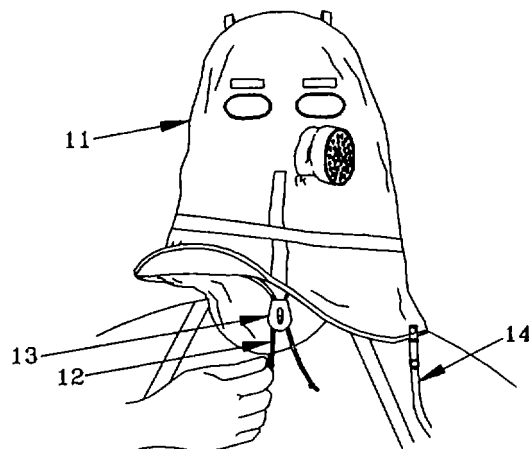
- f. Donning M3 TAP Hood and M9A1 Mask or M40 TAP Special Purpose Hood and M40 Mask

NOTE

M6A2 Hood worn with M17 Mask, and M40 General Purpose Hood worn with M40 Mask are also authorized for wear at Level B and below by DA Pam 385-61. Don in a similar manner as below.



- (1) Pull hood (11) forward over mask, turning the hood (11) inside out.
- (2) Don mask and make necessary adjustments to the head harness IAW TM 3-4240-204-14, TM 3-4240-300-10-1 or TM 3-4240-279-10.



- (3) Flip hood (11) over the head. Pull hood drawcord (12) snug and secure with cord lock (13).
- (4) Drop hood (11) over the shoulders and secure by passing the shoulder straps (14) under the arms, attaching them to the front.

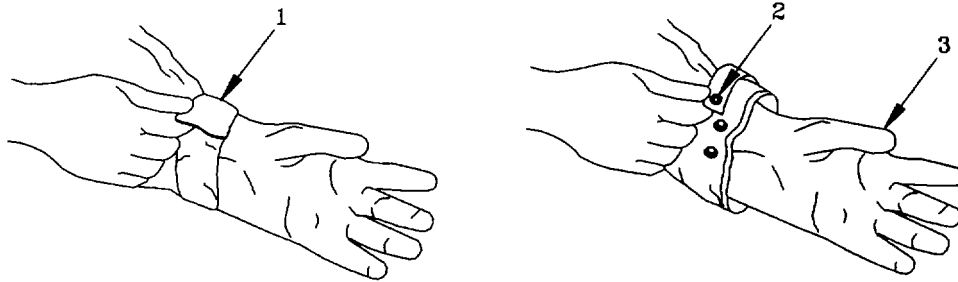
2-6. DONNING TAP ENSEMBLE FOR LEVEL C AND D. Complete steps 2-5.b thru 2-5.f.

2-7. DOFFING TAP ENSEMBLE FOR LEVEL A.

WARNING

The following doffing procedures are to be used only when TAP Ensemble has not been exposed to contamination. For decontamination procedures, refer to FM 3-5 or DA Pam 385-61.

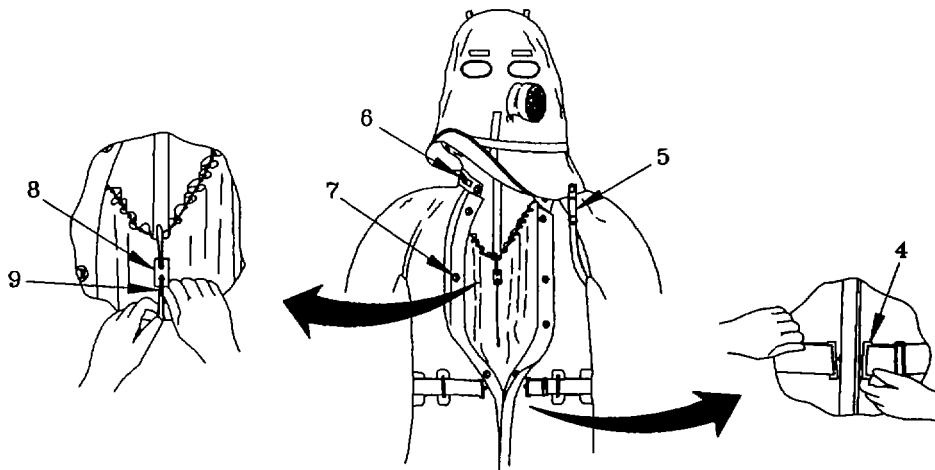
a. Remove M3/M4 TAP Gloves.



(1) Remove tape (1) around cuffs and unfasten each outer sleeve snap fastener (2).

(2) Remove M3/M4 TAP gloves (3).

b. Doffing M3 TAP Coveralls.



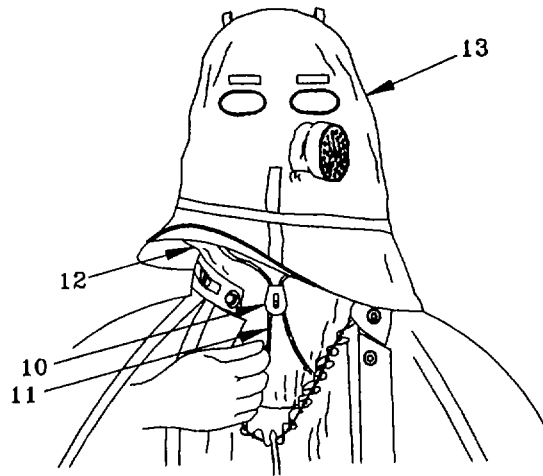
(1) Disconnect belt (4).

(2) Unfasten hood shoulder straps (5).

(3) Loosen neck straps (6) and unfasten all front snap fasteners (7).

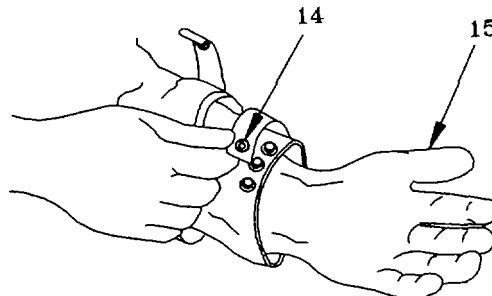
(4) Release coverall gusset cord lock (8) and loosen drawcord (9).

c. Doffing M3 TAP Hood and M9A1 Mask or M3 TAP Special Purpose Hood and M40 Mask.



- (1) Release hood cord lock (10) and loosen neck drawcord (11). Remove inner skirt (11) from under coverall gusset and collar.
- (2) Pull hood (13) forward and remove mask IAW TM 3-4240-204-14 or TM 3-4240-300-10-1.

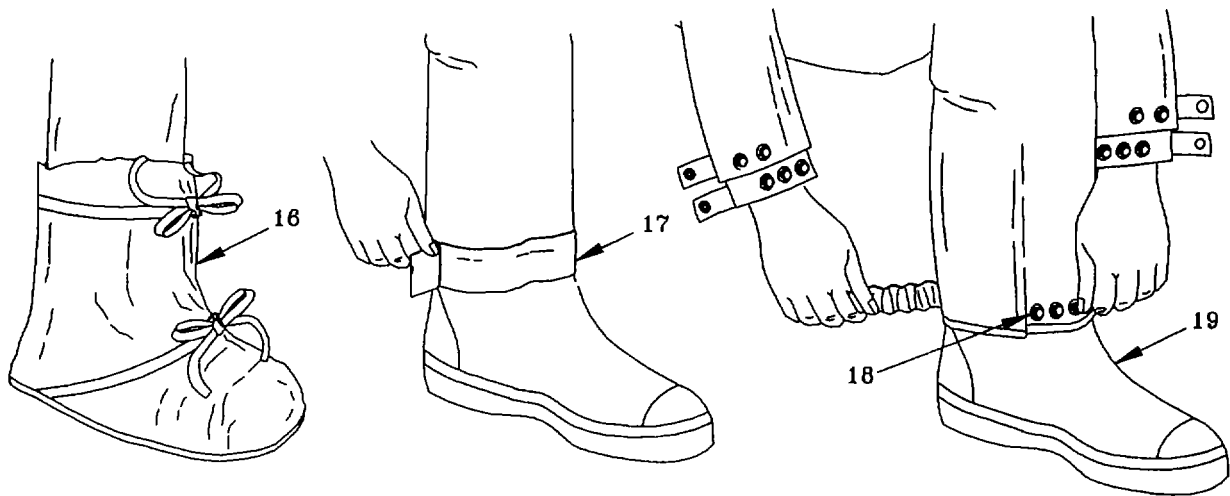
d. Remove Inner Gloves.



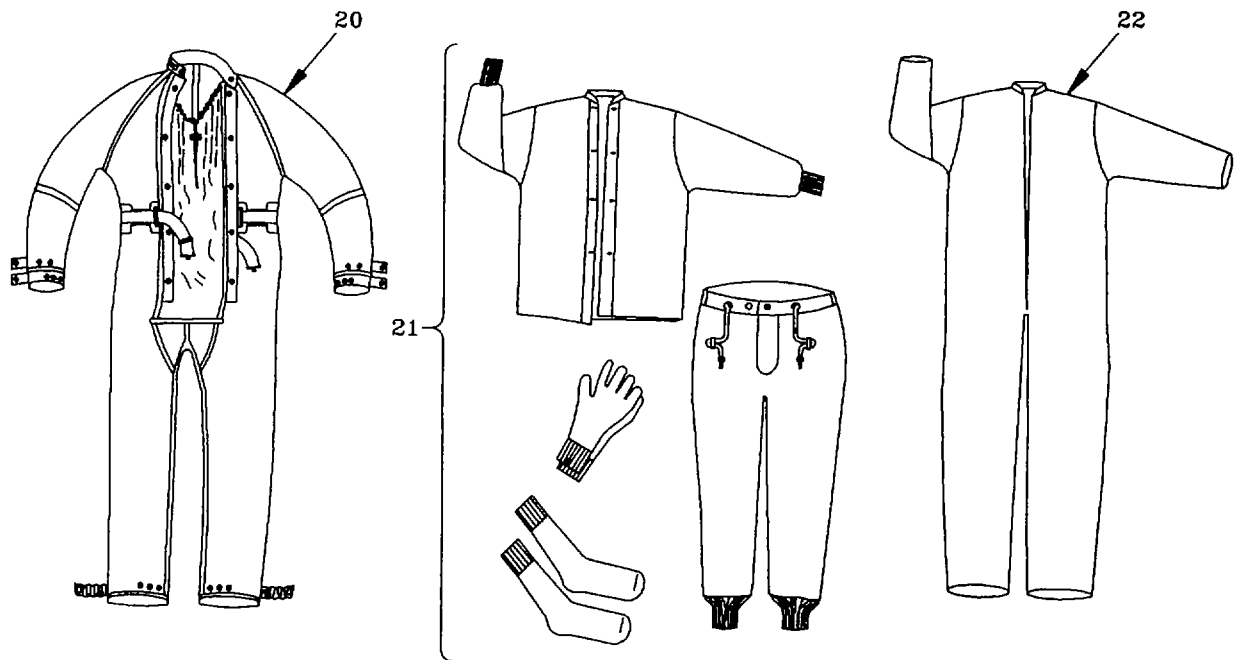
- (1) Unfasten coverall inner sleeve cuff snap fastener (14)
- (2) Remove surgeon's gloves (15) (if worn).

2-7. DOFFING TAP ENSEMBLE FOR LEVEL A. (CONT)

e. Remove M2A1 TAP Boots and M1 TAP Footwear Covers.



- (1) Remove M1 TAP footwear covers (16) (if worn).
- (2) Remove tape (17) from ankles and unfasten each trouser cuff snap fastener (18).
- (3) Remove M2A1 TAP boots (19).



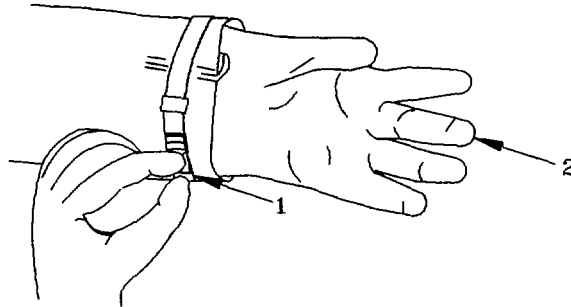
- f. Remove M3 TAP coveralls (20).
- g. Remove clothing outfit (21), BDUs or cloth coveralls (22) as required.

2-8. DOFFING TAP ENSEMBLE FOR LEVEL B.

WARNING

The following doffing procedures are to be used only when TAP ensemble has not been exposed to contamination. For decontamination procedures, refer to FM 3-5 or DA Pam 385-61.

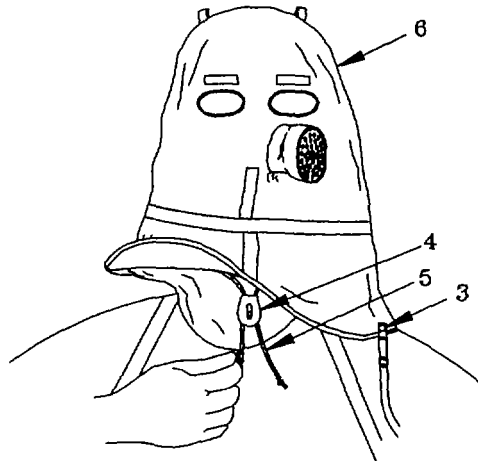
a. Remove M3/M4 TAP Gloves.



(1) Loosen M2 TAP apron sleeve straps (1).

(2) Remove M3/M4 TAP gloves (2).

b. Doffing M3 TAP Hood and M9A1 Mask or M40 TAP Special Purpose Hood and M40 Mask.

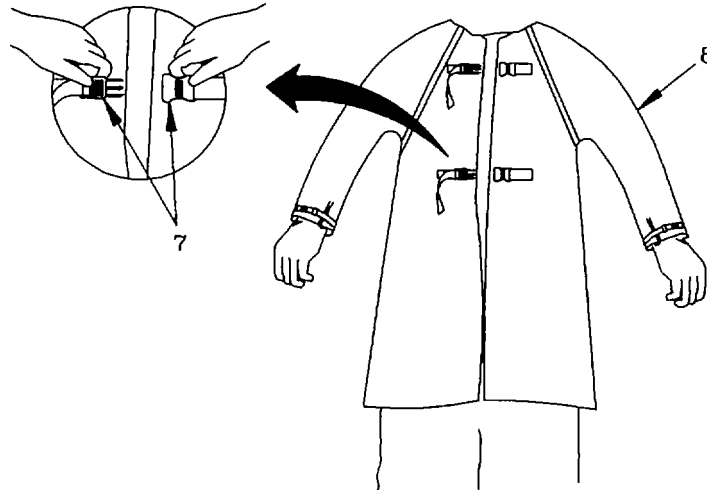


(1) Unfasten hood shoulder strap snap fasteners (3).

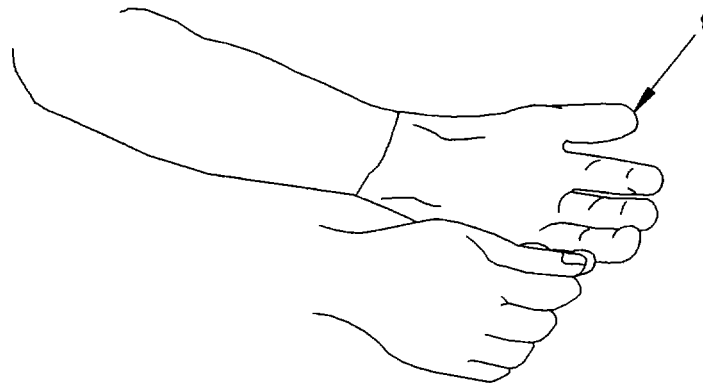
(2) Release cord lock (4) and loosen neck drawcord (5).

(3) Pull hood (6) forward and remove mask IAW TM 3-4240-204-14, TM 3-4240-300-10-1, or TM 3-4240-279-10.

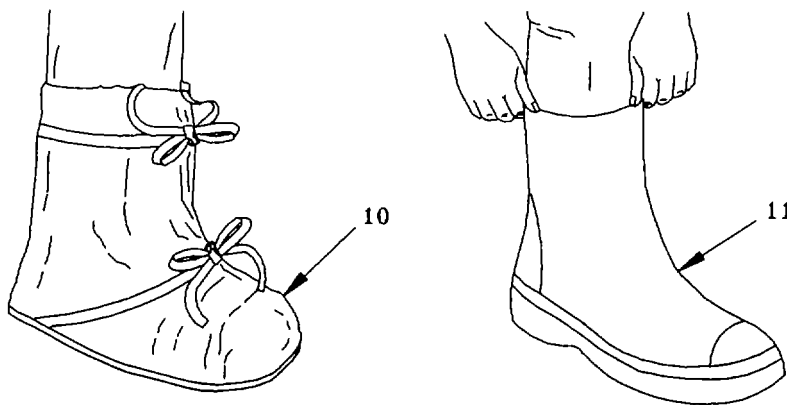
2-8. DOFFING TAP ENSEMBLE FOR LEVEL B. (CONT)



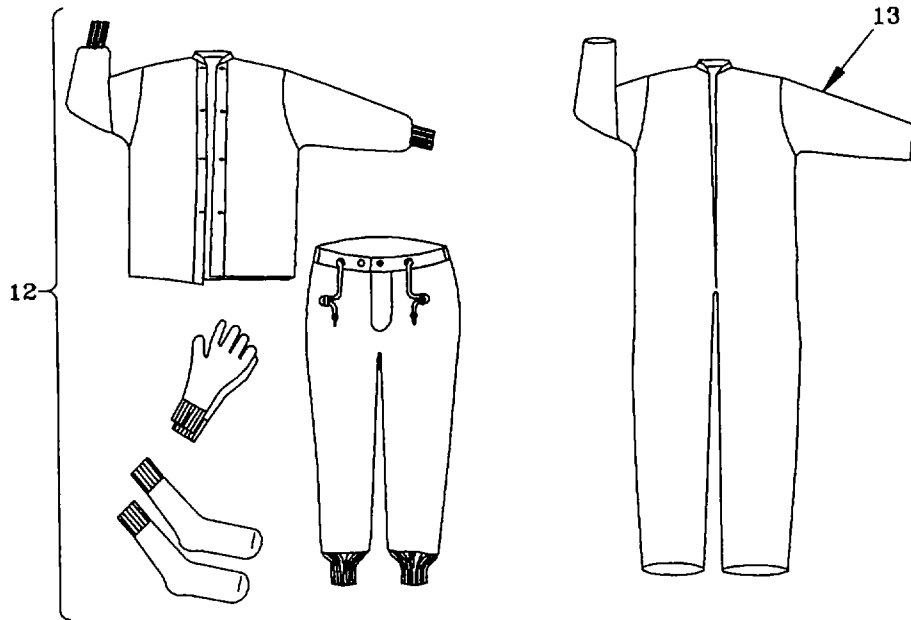
- c. Have a buddy release apron straps (7) and open apron (8).
- d. Remove M2 TAP apron (8).



- e. Remove surgeon's gloves (9) (if worn).
- f. Remove M2A1 TAP Boots and M1 TAP Footwear Covers.



- (1) Remove M1 TAP footwear covers (10) (if worn).
- (2) Remove M2A1 TAP boots (11).



g. Remove clothing outfit (12), BDUs or cloth coveralls (13) as required.

2-9. DOFFING TAP ENSEMBLE FOR LEVEL C AND D. Complete steps 2-8.a thru 2-8.f.

2-10. DECALS AND INSTRUCTION PLATES. The TAP ensemble components will have the next inspection due date stenciled on them with stencil ink.

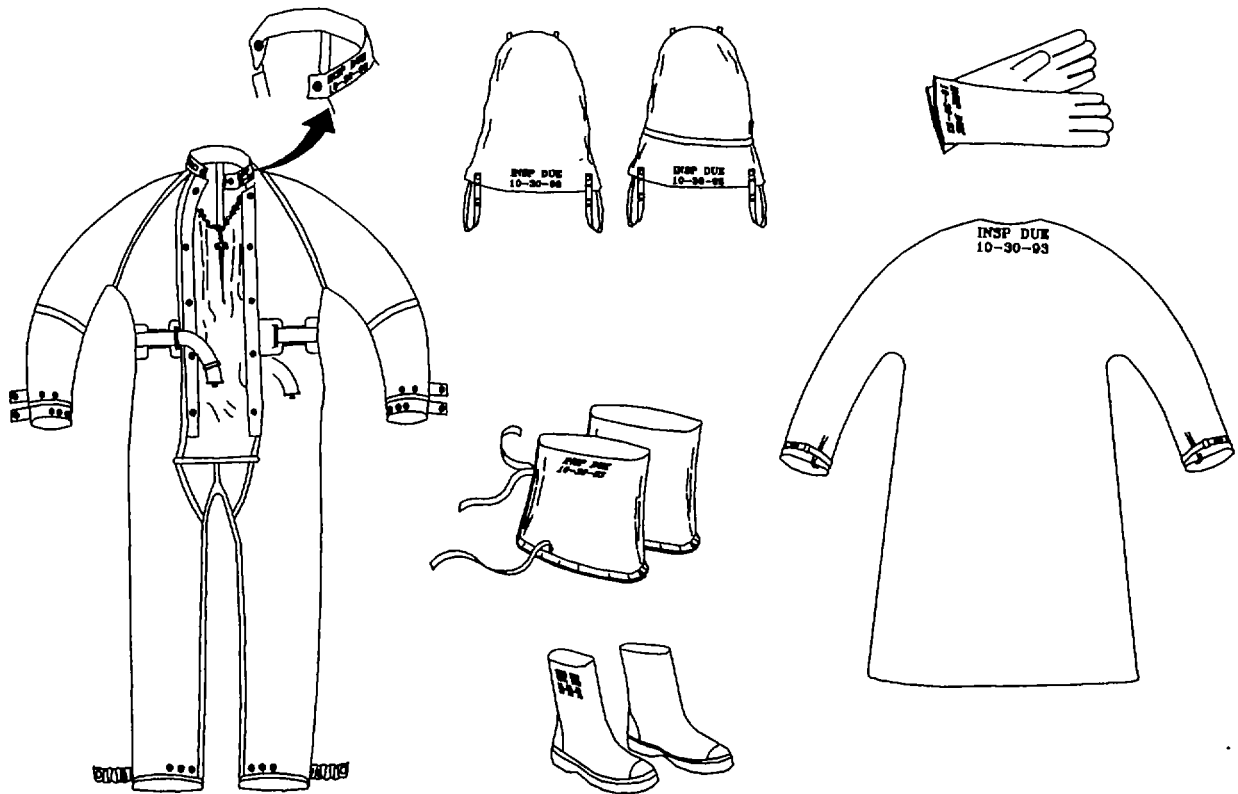


Figure 2-1. Inspection Due Dates on TAP Ensemble Components

Section III. OPERATION UNDER UNUSUAL CONDITIONS

2-11. WEAR TIME LIMITATIONS. The maximum wearing time for personnel working in the TAP Ensemble will vary greatly depending on several factors, such as temperature, relative humidity, individual training status, and physical condition. Guidelines, for one-time wear, to prevent heat injury and ensure personal safety while wearing the full TAP Ensemble are presented in AR 385-61 and DA PAM 385-61. The wearer's recuperating time prior to donning the ensemble for repetitive use generally should be equivalent to three times the period of time the Ensemble is worn. However, the final decision regarding the appropriate recuperating time will be determined by the Commander, with the advice of medical authorities.

2-12. DOFFING THE TAP ENSEMBLE IN A CHEMICAL ENVIRONMENT. Doffing contaminated TAP ensemble components is done in accordance with FM 3-5, AR 385-61 and DA PAM 385-61.

2-13. EMERGENCY DOFFING OF THE TAP ENSEMBLE. If the wearer becomes a casualty from excessive heat stress, emergency doffing of the TAP Ensemble is authorized. Casualty decontamination and doffing procedures will be performed IAW FM 3-5.

CHAPTER 3

OPERATOR MAINTENANCE INSTRUCTIONS

Subject	Page
Section I OPERATOR MAINTENANCE PROCEDURES	3-1
3-1 INSPECTION	3-1
3-2 CLEANING	3-1

Section I. OPERATOR MAINTENANCE PROCEDURES

3-1. INSPECTION. Perform inspection as described in Chapter 2, Section II, PMCS. Report defects on DA Form 2404.

3-2. CLEANING. Clean all TAP Ensemble components that have been worn in a suspect environment and not subject to liquid or vapor contamination by flushing fully with fresh water. Air-dry the components for a minimum of 12 hours prior to next use, hanging components by suspension straps only or placing boots and gloves on pallets a minimum of 6 inches off the floor.

CHAPTER 4

UNIT MAINTENANCE INSTRUCTIONS

Subject	Page
Section I	
REPAIR PARTS; SPECIAL TOOLS; TEST, MEASUREMENT, AND DIAGNOSTIC EQUIPMENT (TMDE); AND SUPPORT EQUIPMENT	4-1
4-1 GENERAL	4-1
Section II	
SERVICE UPON RECEIPT	4-1
4-2 SERVICE UPON RECEIPT OF MATERIEL	4-1
Section III	
PREPARATION FOR STORAGE OR SHIPMENT	4-2
4-3 PREPARATION FOR STORAGE	4-2
4-4 PRESERVATION	4-2
4-5 PREPARATION FOR SHIPMENT	4-2

Section I. REPAIR PARTS, SPECIAL TOOLS, TEST, MEASUREMENT, AND DIAGNOSTIC EQUIPMENT (TMDE), AND SUPPORT EQUIPMENT.

4-1. GENERAL. No unit level maintenance (operator, crew, organization) is authorized for the TAP Ensemble.

Section II. SERVICE UPON RECEIPT

4-2. SERVICE UPON RECEIPT OF MATERIEL.

a. Unpacking. The TAP Ensemble components, will be packaged in shipping containers conforming to PPP-B-636, placed on 4-way entry pallets in accordance with load type IAW MIL-STD-147. Bonding will be with primary and secondary straps. Upon receipt, check for damage. Report any damage to the carrier and your supervisor.

CAUTION

Unpack components carefully. Improper or hasty handling may result in damage to the TAP Ensemble components.

- (1) Cut and remove retaining straps holding containers to pallet. Remove containers from wooden pallet.
- (2) Open the containers, remove padding material, and contents. Do not cut, rip, or otherwise damage the heat sealed bags.
- (3) Do not open garment packages until prior to use.

b. Shipping Material. Save the shipping crate and any padding material for reuse, when possible.

c. Checking Unpacked Equipment. Inspect the unpacked components for damage, completeness, and application of applicable Modification Work Orders (MWOs) as follows:

4-2. SERVICE UPON RECEIPT OF MATERIEL. (CONT)

(1) Damage. Check the equipment for damage incurred during shipment. Report any damage on DD Form 6, Packaging Improvement Report. Also note damage on DA Form 2404, Equipment Inspection and Maintenance Worksheet, and initiate corrective maintenance procedures in accordance with Section III of this chapter.

(2) Completeness. Inspect the contents of the shipment against the packing slip to see if any items are missing (See Appendix C, Components of End Item). Report any discrepancies noted in accordance with instructions in DA Pam 738-750. The equipment can be placed in service even if accessory or other parts/assemblies that are not affecting proper functioning, are missing.

(3) Modifications. Check DA Pam 25-30 to see if there is any MWO applicable to the TAP Ensemble components you are unpacking. If an MWO is listed, check DA Form 2408-5 Equipment Modification Record, to see if it has been applied to the equipment. The MWO number will be shown on the case/bag near the equipment nomenclature. If a current MWO is listed in DA Pam 25-30 but there is no evidence that it has been applied to the equipment you are unpacking, note discrepancy on DA Form 2404, Equipment Inspection and Maintenance Worksheet.

Section III. PREPARATION FOR STORAGE OR SHIPMENT

4-3. PREPARATION FOR STORAGE. To prepare the TAP Ensemble equipment for storage, clean and dry the components as described in paragraph 3-3. Perform operator PMCS as specified in Table 2-1. Store all items of protective clothing in a clean dry place. Hang coveralls and hood by suspension loops attached to each item. Store gloves, flat without crushing or folding. Store boots on dunnage at least six inches from floor. Place unopened bags onto a wooden pallet and store.

a. Special Instructions for Administrative Storage. Placement of equipment in administrative storage should be for short periods of time when a shortage of maintenance resources exist. Items should be in mission readiness within 24 hours or within the time factors as determined by the directing authority. Appropriate maintenance records will be kept during storage. Before placing equipment in administrative storage, current maintenance services and Equipment Serviceability Criteria (ESC) evaluations should be completed, shortcomings and deficiencies should be corrected, and all Modification Work Orders (MWOs) should be applied.

b. Storage site selection. Inside storage is preferred for items selected for administrative storage. If inside storage is not available trucks, vans, conex or other containers may be used.

4-4. PRESERVATION. If the TAP Ensemble components are to be stored without regular PMCS being performed, consult TM 38-230-2 for preservation requirements.

4-5. PREPARATION FOR SHIPMENT. Prepare the TAP Ensemble for shipment by packing components into original or similar containers, in which they were received. Strap containers onto wooden pallet.

CHAPTER 5

DIRECT SUPPORT MAINTENANCE INSTRUCTIONS

Subject	Page
Section I REPAIR PARTS, SPECIAL TOOLS; TEST MEASUREMENT DIAGNOSTIC EQUIPMENT (TMDE) AND SUPPORT EQUIPMENT	5-1
5-1 COMMON TOOLS AND EQUIPMENT	5-1
5-2 SPECIAL TOOLS, TMDE, AND SUPPORT EQUIPMENT	5-1
5-3 REPAIR PARTS	5-1
Section II DIRECT SUPPORT PREVENTIVE MAINTENANCE CHECKS AND SERVICES (PMCS)	5-2
5-4 GENERAL	5-2
Section III MAINTENANCE PROCEDURES	5-2
5-5 GENERAL	5-2
5-6 DECONTAMINATE	5-2
5-7 LAUNDERING TAP M3 TAP/M40 TAP SPECIAL PURPOSE HOODS, M2A1 TAP BOOTS, M3 TAP COVERALLS, M1 TAP FOOTWEAR COVERS, M3/M4 TAP GLOVES, M2 TAP APRON	5-2
5-8 STITCHES, SEAMS AND STITCHING	5-3
5-9 PATCH REPAIRS IN BUTYL MATERIAL	5-4
5-10 REPAIR STRAPPING AND TUNNELS.....	5-7
5-11 REPLACE SNAP FASTENERS.....	5-10
5-12 M3 TAP AND M40 TAP SPECIAL PURPOSE HOODS	5-13
5-13 M2A1 TAP BOOTS	5-16
5-14 M3 TAP COVERALLS	5-18
5-15 M1 TAP FOOTWEAR COVERS	5-27
5-16 M3/M4 TAP GLOVES.....	5-28
5-17 M2 TAP APRON.....	5-30
5-18 LAUNDERING THE CHEMICAL PROTECTIVE CLOTHING OUTFIT.....	5-33

Section I. REPAIR PARTS, SPECIAL TOOLS; TEST MEASUREMENT DIAGNOSTIC EQUIPMENT (TMDE) AND SUPPORT EQUIPMENT

5-1. COMMON TOOLS AND EQUIPMENT . For authorized common tools and equipment refer to the Modified Table of Organization and Equipment (MTOE) applicable to your unit.

5-2. SPECIAL TOOLS, TMDE, AND SUPPORT EQUIPMENT . Special tools and equipment required to test and repair the TAP Ensemble are listed in Appendix B, Section III, and in the individual maintenance procedure.

5-3. REPAIR PARTS. Repair Parts are listed and illustrated in Appendix C Repair Parts and Special Tools List (RPSTL).

Section II. DIRECT SUPPORT PREVENTIVE MAINTENANCE CHECKS AND SERVICES (PMCS)

5-4. GENERAL. PMCS is performed on the TAP Ensemble components on a quarterly basis, after initial issue, or after decontamination and laundering. Quarterly PMCS procedures for the M3 TAP Hood, M40 TAP Special Purpose Hood, M2A1 TAP Boots, M3 TAP Coveralls, M1 TAP Footwear Covers, M3/M4 TAP Gloves, M2 TAP Apron and Clothing Outfit are described in Table 2- 1. Detailed inspection procedures for the M3 TAP Coveralls are listed in paragraph 5-15. Record all defects found during the performance of PMCS and the steps taken to correct them on a DA Form 2404, Equipment Inspection and Maintenance Worksheet. Instructions for reporting/correcting noted deficiencies are contained in DA Pam 738-750.

Section III. MAINTENANCE PROCEDURES

5-5. GENERAL. Direct Support maintenance repair functions include service, replace, repair of stitching, seam strapping and patching of material. Common guidance for those repairs is provided in paragraphs 5-8 thru 5-11 and FM 10-16. Item specific procedures are provided under each unique repair procedure. Laundering instructions are provided in paragraph 5-7 and 5-18.

5-6. DECONTAMINATION. Decontaminate the TAP Ensemble components IAW procedures in FM 3-5, TM 60A-1-1-11, or DA Pam 385-61.

5-7. LAUNDERING TAP M3 TAP/M40 TAP SPECIAL PURPOSE HOODS, M2A1 TAP BOOTS, M3 TAP COVERALLS, M1 TAP FOOTWEAR COVERS, M3/M4 TAP GLOVES, M2 TAP APRON.

This task covers: a. Washing
b. Drying

NOTE

TAP Ensemble components worn in a contaminated environment will be laundered in accordance with DA Pam 385-61.

INITIAL SETUP

Tools:

Thermometer (Appendix F, Item 22)
Measuring Cup (Appendix F, Item 7)

Materials/Parts:

Laundry Soap, Powdered (Appendix F, Item 17)
pH Paper (Appendix F, Item 15)

Equipment Condition: N/A

a. Washing.

CAUTION

Do not use detergents in place of soap as this may damage the butyl material.

- (1) Soak in hot soapy water with an alkalinity of pH 8 to pH 9 at a temperature of 140°F (60°C) for at least one hour with no agitation.

(2) Rinse clothing with fresh water.

b. Drying.

(1) Air dry clothing.

CAUTION

Do not use clothes pins to hang TAP components as this may damage the material.

(2) Place items in ventilated area to aerate for a 24-hour period. Drape items over clothes line or place on rack if available.

5-8. STITCHES, SEAMS AND STITCHING.

a. General. All stitches, seams and stitching shall conform to FED-STD-751. The type of seam, stitching and stitches per inch shall be as specified in individual repair procedures. Seam allowances shall be maintained with seams sewn so that no raw edge, run-off, twists, pleats, puckers or open seams occur. Automatic stitching machines may be used to perform any of the required stitch patterns provided the requirements of the stitch pattern, stitches per inch, size and type of thread are met, and at least three or more overlapping, tying or backstitches secure the ends of the stitching.

b. Type 301 Stitching. Ends of all 301 stitching, except when caught in other seams or stitching, shall be backstitched or overstitched 1/2 inch minimum. Thread tension shall be maintained so that there will be no loose stitching resulting in loose bobbin or top thread, or excessively tight stitching resulting in puckering of the materials sewn. The lock shall be embedded in the materials sewn.

(1) *Repairs of Type 301 Stitching.*

(a) When thread breaks or bobbin run-outs occur during sewing, the stitching shall be repaired by restarting the stitching a minimum of 1/2 inch back of the end of stitching.

(b) Thread breaks or two or more consecutive runoff or skipped stitches noted during inspection of the item shall be repaired by overstitching. The stitching shall start a minimum of 1/2 inch in back of the defective area, continue over the defective area and continue a minimum of 1/2 inch beyond the defective area onto the existing stitching. Loose or excessively tight stitching shall be repaired by removing the defective stitching, without damaging the materials, and restitching in the required manner.

(2) *Thread Ends.* All thread ends shall be trimmed to a length of not more than 1/4 inch.

(3) *Bartacking.* Bartacking shall be $1/2 \pm 1/16$ inch in length and $1/8 \pm 1/32$ inch in width and shall contain 28 stitches. Bartacking shall be free from thread breaks or loose or tight stitching.

c. Type 401 Stitching. Thread tension shall be maintained so that there will be no loose stitching resulting in loose bobbin or top thread, or excessively tight stitching resulting in puckering of the materials sewn. The lock shall be embedded in the materials sewn. Type 301 stitching may be used to perform the repairs.

(1) *Repairs of Type 401 Stitching.* Repairs to Type 401 stitching will be made according to Type 301 stitching instructions.

5-8. STITCHES, SEAMS AND STITCHING. (CONT)

- (2) Thread Ends. All thread ends shall be trimmed to a length of not more than $\frac{1}{4}$ inch.
- (3) Bartacking. Bartacking shall be $\frac{3}{8} \pm \frac{1}{16}$ inch in length and $\frac{1}{8} \pm \frac{1}{32}$ inch in width and shall contain 28 stitches. Bartacking shall be free from thread breaks or loose or tight stitching.

5-9. PATCH REPAIRS IN BUTYL MATERIAL.

- This task covers:
- a. General Repair Instructions
 - b. Repair Punctures Less than $\frac{1}{2}$ inch Diameter
 - c. Repair Tears up to 3 inches Long
 - d. Repair Tears over 3 inches Long and Holes Greater than $\frac{1}{4}$ inch in Diameter
 - e. Patching Instructions

INITIAL SETUPTools:

Maintenance Kit (Appendix B, Section III, Item 2)
 Roller, Hand (Appendix B, Section III, Item 3)

Materials/Parts:

Adhesive, Carboline (Appendix F, Item 3)
 Alcohol, Isopropyl (Appendix F, Item 4)
 Cloth, Nylon, Butyl Rubber Coated
 Talc, Tech (Appendix F, Item 21)

a. General Repair Instructions. Component areas containing holes or tears may be repaired by the application of two superimposed patches of similar material to both sides of the item. Areas containing surface defects that do not extend through the material may be repaired by the application of a single patch to the outside of the item. All patches shall be made from serviceable material obtained from maintenance kit, bulk material, or salvaged items. A patch shall be smoothly and evenly adhered to the material so that when subjected to flexing action, will show no lifting at the edges, cracking, flaking or removal of the cement or patch. The repaired area shall show no stiffening or tackiness which would effect the serviceability of the component. In no case shall patches be applied to seams. Repair of fabric coating defects by methods other than patching is not authorized.

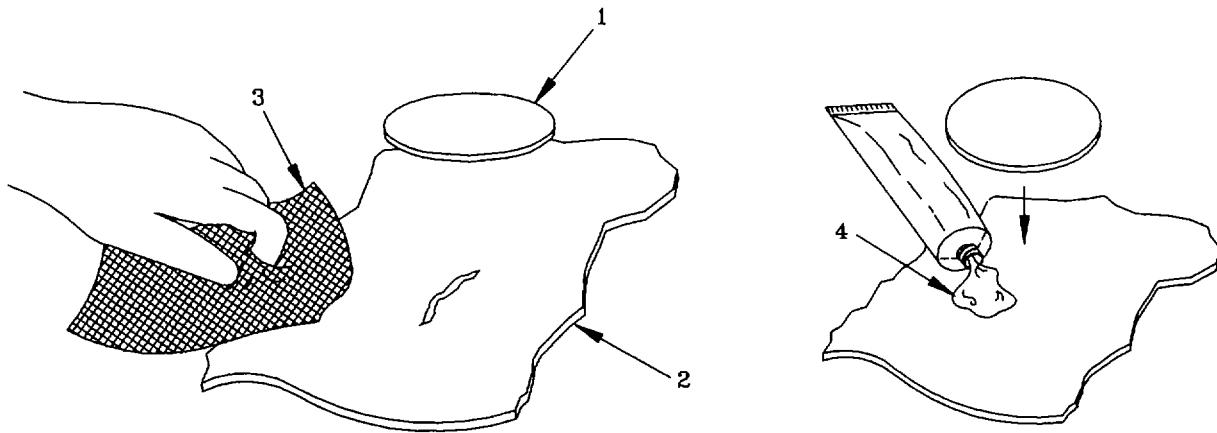
b. Repair Punctures Less than $\frac{1}{2}$ inch Diameter. Use of pre-cut patches obtained from maintenance kit is authorized. Patch shall be at least $\frac{1}{2} \pm \frac{1}{4}$ inch in diameter.

c. Repair Tears up to 3 inches Long. Tears up to 3 inches in length, but $\frac{1}{2}$ inch or less in width may be repaired using patches cut at least 1 inch larger than the damaged area on all sides.

d. Repair Tears over 3 inches Long and Holes Greater than $\frac{1}{2}$ inch in Diameter. Repair of tears longer than 3 inches or holes greater than $\frac{1}{2}$ inch diameter is not authorized.

e. Patching Instructions.

- (1) Obtain a patch as required by paragraphs a., b., c. or d. above.

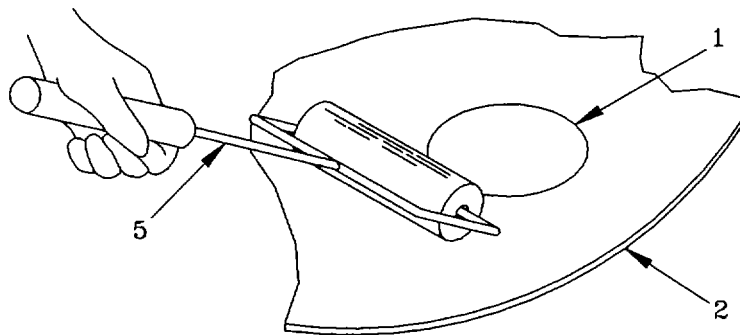


- (2) Clean and roughen the patch (1) and the garment (2) with an abrasive strip (3).

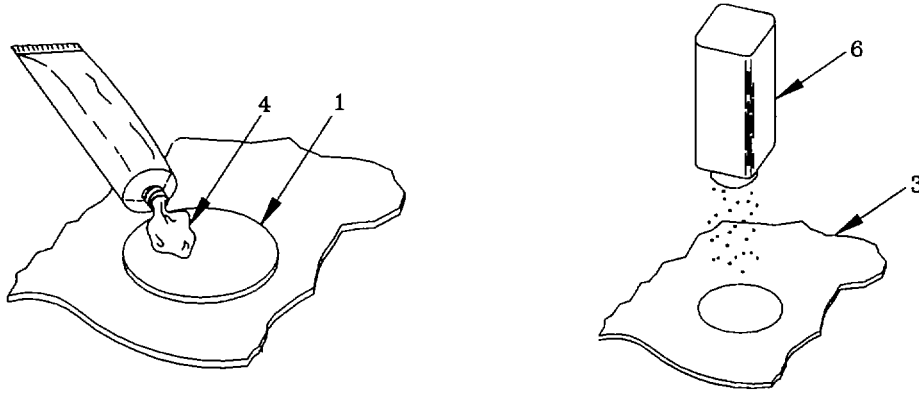
WARNING

Use maintenance kit adhesive in a well ventilated area only and avoid skin contact. Wear proper protective equipment. Failure to do so may result in light-headedness or a burning sensation to the eyes and skin. In case of skin contact, wash with soap and water. If vapors become strong, leave the area and allow to ventilate.

- (3) Apply a coating of adhesive (4) to the patch (1) and the garment (2), and allow the cemented areas to become tacky to the touch.



- (4) Place the patch (1) on the garment (2) to cover the damaged area, and press the patch (1) firmly in place with hand roller (5).

5-9. PATCH REPAIRS IN BUTYL MATERIAL. (CONT)

- (5) After the patch (1) sets, apply adhesive (4) to the patched area, and allow it to become tacky to the touch.
- (6) Apply a light coat of powdered talc (6) to the patched area to prevent it from adhering to other portions of the garment (3).
- (7) If required by paragraph a. above, patch the garment on the reverse side by turning it inside out and repeating steps (1) - (6).

5-10. REPAIR STRAPPING AND TUNNELS.

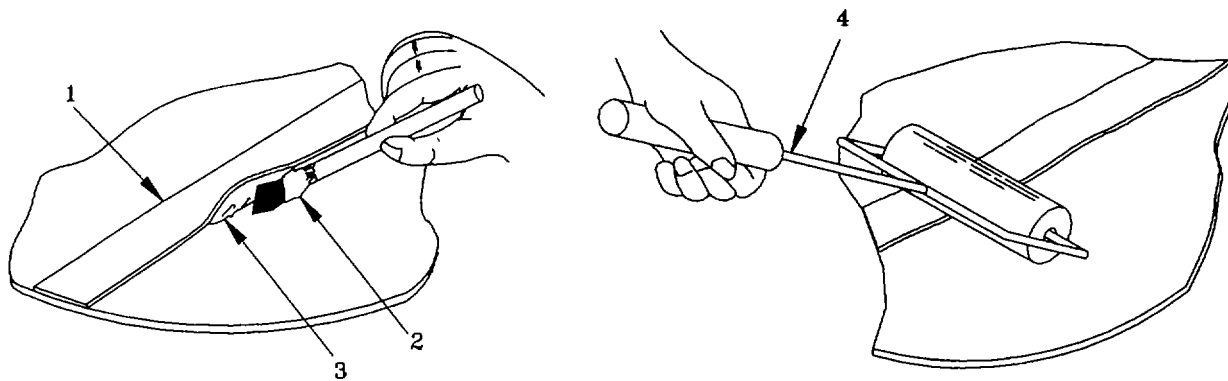
This task covers: a. Repair Detached Strapping
b. Repair Tunnels in Strapping.

INITIAL SETUPTools:

File, Hand (Appendix F, Item 8)
Needle, 18 gauge (Appendix F, Item 14)
Roller, Hand (Appendix F, Item 16)
Syringe, Glass (Appendix F, Item 19)

Materials/Parts:

Adhesive, Carboline (Appendix F, Item 3)
Alcohol, Isopropyl (Appendix F, Item 4)
Brush, Acid Swabbing (Appendix F, Item 5)
Probing Device (e.g., paper clip)
Talc, Tech (Appendix F, Item 21)
Toluene (Appendix F, Item 23)

a. Repair Detached Strapping.

(1) Clean area where strapping (1) has been removed.

WARNING

Use maintenance kit adhesive in a well ventilated area only and avoid skin contact. Wear proper protective equipment. Failure to do so may result in light-headedness or a burning sensation to the eyes and skin. In case of skin contact, wash with soap and water. If vapors become strong, leave the area and allow to ventilate.

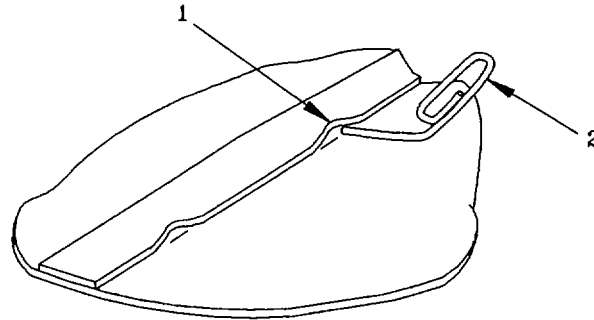
(2) Use brush (2) to apply adhesive (3) underneath strapping (1).

(3) After 1-2 hours, roll strapping (1) firmly with hand roller (4).

(4) Apply a light coat of talc to the repaired area to prevent it from adhering to other parts of the garment.

5-10. REPAIR STRAPPING AND TUNNELS. (CONT)

b. Repair Tunnels.

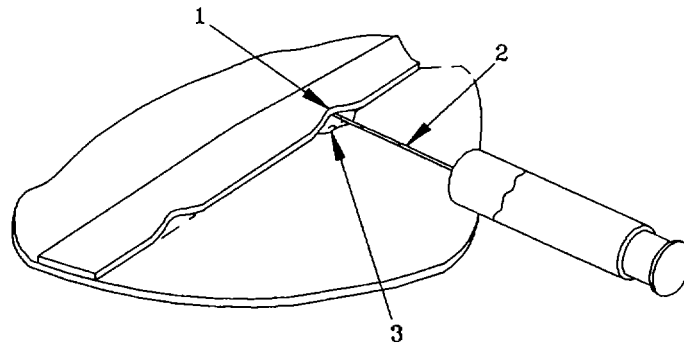


(1) Probe the suspected tunnel (1) with a blunt object (such as a paper clip) (2) to measure its depth.

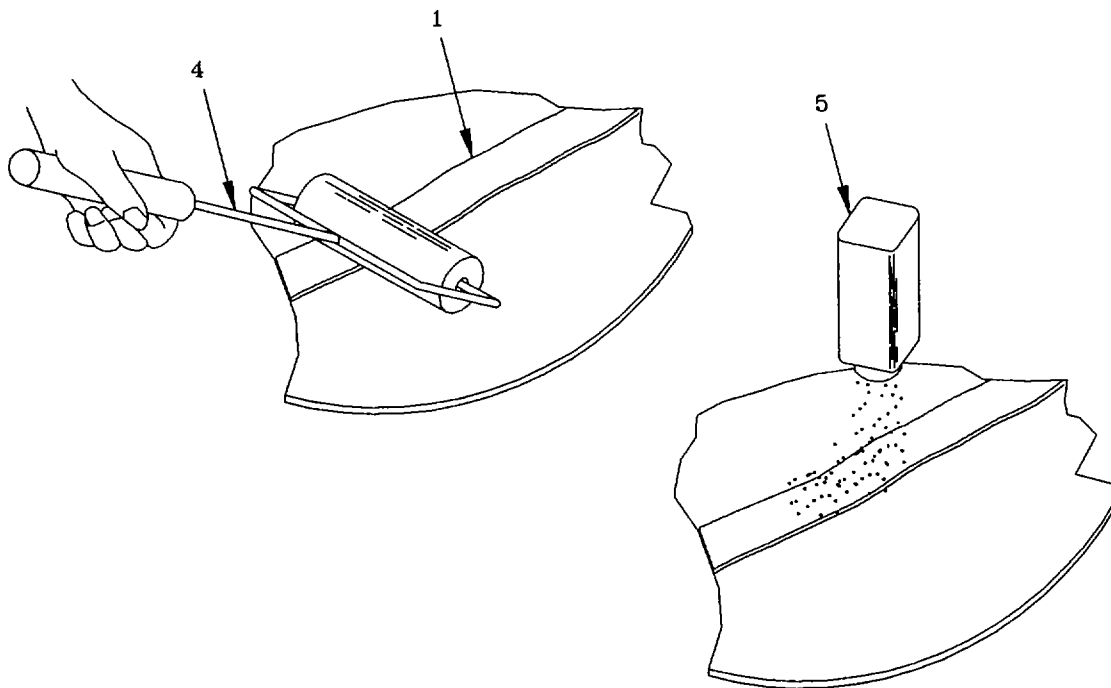
(2) Use file to blunt an 18 gauge needle.

WARNING

- **Use maintenance kit adhesive in a well ventilated area only and avoid skin contact. Wear proper protective equipment. Failure to do so may result in light-headedness or a burning sensation to the eyes and skin. In case of skin contact, wash with soap and water. If vapors become strong, leave the area and allow to ventilate.**
 - **Toluene is extremely flammable and its vapors toxic. Use toluene in a well-ventilated area away from any source of heat. Death or severe injury may result from explosion, fire or fume inhalation. If vapors become strong, leave area and allow to ventilate. In case of skin contact, wash with soap and water.**
- (3) Attach needle to 10 ml glass syringe and fill syringe with adhesive. Adhesive may be thinned by adding toluene.



- (4) Insert needle (2) into tunnel (1), avoiding puncturing the material. Inject adhesive (3) until tunnel (1) is filled or excess adhesive (3) leaks out around the needle (2).



- (5) After 1-2 hours, roll strapping (1) firmly with hand roller (4).
- (6) Apply a light coat of talc (5) to the repaired area to prevent it from adhering to other parts of the garment.

5-11. REPLACE SNAP FASTENERS.

This task covers: a. Preparing Material
b. Installing Female Section
c. Installing Male Section

INITIAL SETUPTools:

Snap Setting Tool (Appendix B, Section III, Items 5 and 6)

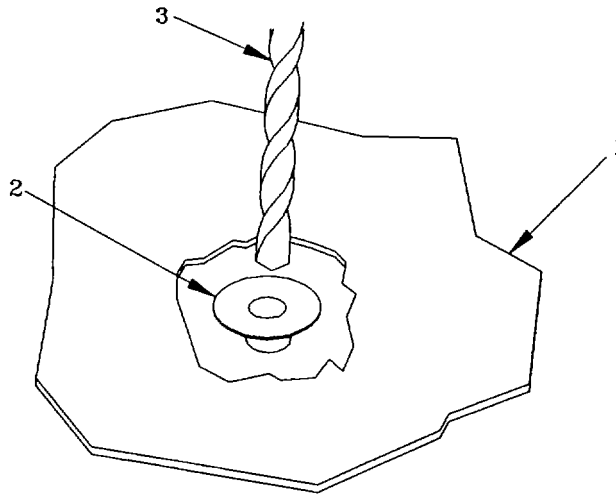
Materials/Parts:

Snap Fastener (Appendix C-1, Item 2; C-2, Item 2 and 5)

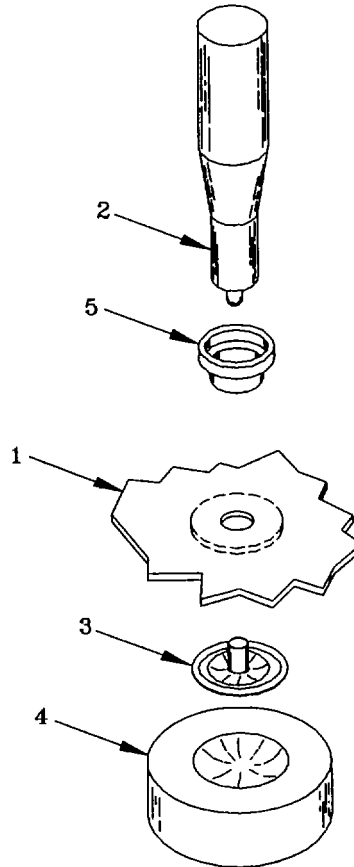
NOTE

Snap fastener replacement procedures are for use when snap fastener has failed, but material is not damaged.

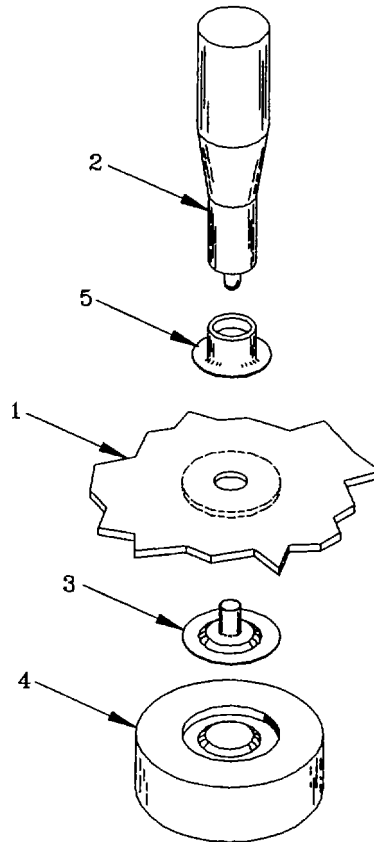
- a. Preparing the Material.



- (1) Place the material (1) on a hard surface with barrel of the snap fastener (2) down.
- (2) Hold material (1) firmly in place and ream out flanged end of the snap fastener barrel (2) with a drill (3). Separate the fastener halves.
- (3) Patch the material (1) where the snap fastener was removed IAW paragraph 5-9, except for female snap fasteners on hood straps, then no patch is applied.

b. Installing Female Section.

- (1) Cut a hole in the material (1), using a tube of the revolving punch (2). The hole should be small enough for a tight fit around the barrel of cap (3).
- (2) Insert the barrel of cap (3) through the hole in the material (1).
- (3) Place the inserted cap (3), barrel up, on the anvil (4).
- (4) Fit the socket (5) over the barrel of cap (3).
- (5) Place the cap-and-post set on the barrel of the cap (3), and clinch the cap (3) and socket (5) to the material (1) with a hammer blow.

5-11. REPLACE SNAP FASTENERS. (CONT)c. Installing Male Section.

- (1) Cut a hole in the patched material (1), using a tube of the revolving punch (2). The hole should be small enough for a tight fit around the barrel of the post (3).
- (2) Insert the barrel of the post (3) through the hole in the material (1) from the underside of the material.
- (3) Place the inserted post (3), barrel up, on the anvil (4).
- (4) Fit the stud (5) over the barrel of the post (3).
- (5) Place the cap-and-post set on the barrel of the post (3), and clinch the post (3) and stud (5) to the material (1) with a hammer blow.

5-12. M3 TAP AND M40 TAP SPECIAL PURPOSE HOODS.

- This task covers:
- a. Inspect M3 TAP/M40 TAP Special Purpose Hoods
 - b. Repair Stitching
 - c. Repair Hood Material
 - d. Repair Strapping and Tunnels
 - e. Replace Snap Fasteners
 - f. Replace Shoulder Straps

INITIAL SETUPTools:

Maintenance Kit (Appendix B, Section III, Item 2)
 Roller, Hand (Appendix B, Section III, Item 4)
 Sewing Machine (Appendix B, Section III, Item 5)

Materials/Parts:

Adhesive, Carboline (Appendix F, Item 3)
 Alcohol, Isopropyl (Appendix F, Item 4)
 Buckle, Tongueless (Appendix C-1, Item 1)
 Chalk, White (Appendix F, Item 1)
 Cloth, Nylon, Butyl Rubber Coated (Appendix C-1, Item 3)
 Ink Pad, Rubber Stamp (Appendix F, Item 11)
 Ink, Stencil (Appendix F, Item 12)
 Snap Fastener (Appendix C-1, Item 2)
 Stencil Roller (Appendix F, Item 18)
 Thread, Polyester (Appendix C-1, Item 4)
 Talc, Tech (Appendix F, Item 13)

a. Inspect. Inspect hood in accordance with procedures outlined in Table 2-1. Use Equipment Inspection and Maintenance Worksheet DA Form 2404 to record all defects found. The maximum number of patches allowed on the outside of hood is 15 or 10 in any one of the seven major sections. If inspection reveals a condition that renders the hood unserviceable, turn-in IAW local SOP, otherwise, stencil hood with next inspection due date.

b. Repair Stitching. Repair stitching IAW procedures in paragraph 5-8. All stitching shall be Type 301, with 8 - 10 stitches per inch. See paragraph 5-8.

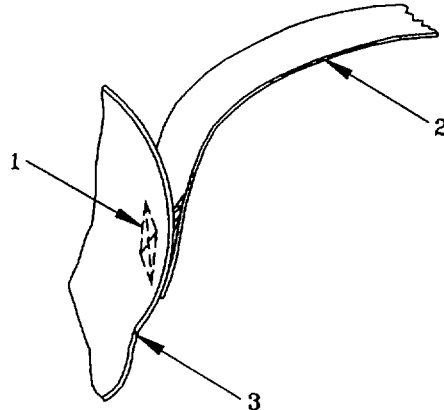
c. Repair Hood Material. No more than 15 patches may be applied to the outside and no more than 10 may be applied to the outside of any of the seven major sections of the hood. Repair IAW paragraph 5-9.

d. Repair Strapping and Tunnels. Repair strapping and tunnels IAW paragraph 5-10.

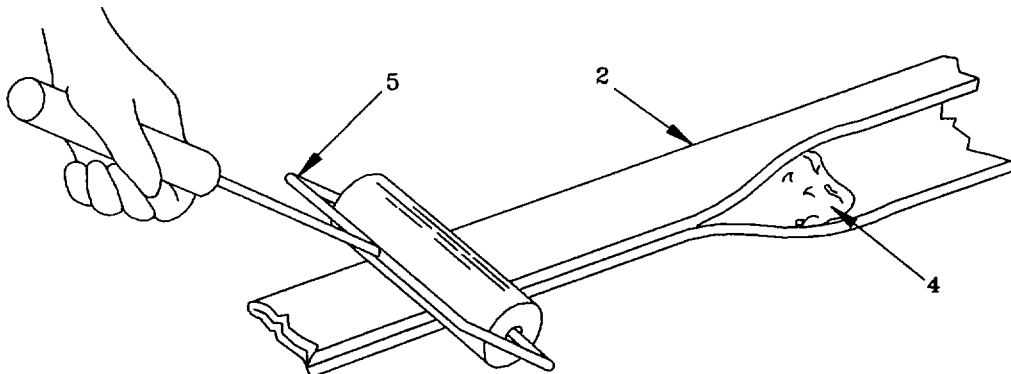
e. Replace Snap Fasteners. Replace snap fasteners IAW paragraph 5-11.

5-12. M3 TAP AND M40 TAP SPECIAL PURPOSE HOODS. (CONT)

f. Replace Shoulder Straps.

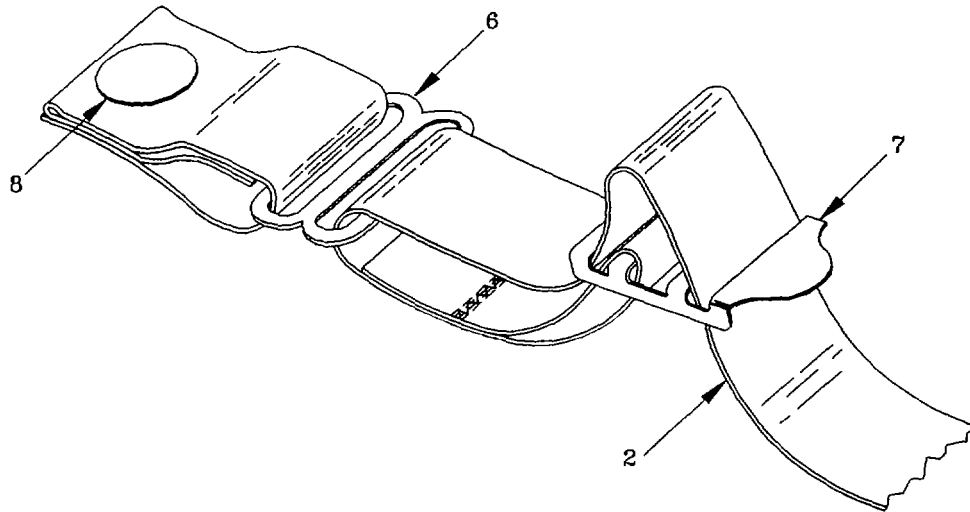


- (1) Remove the stitching (1) that secures the shoulder straps (2) to the hood (3). Separate the cemented fabric, where applicable by pulling it apart, and remove the straps (2) from the hood (3).
- (2) Obtain a shoulder strap (2) from salvage, or fabricate one as follows:
 - (a) Measure an undamaged strap (2) (to include folds and turn unders), and cut a length from bulk stock or salvaged material (also see Appendix G, Illustrated List of Manufactured Items).

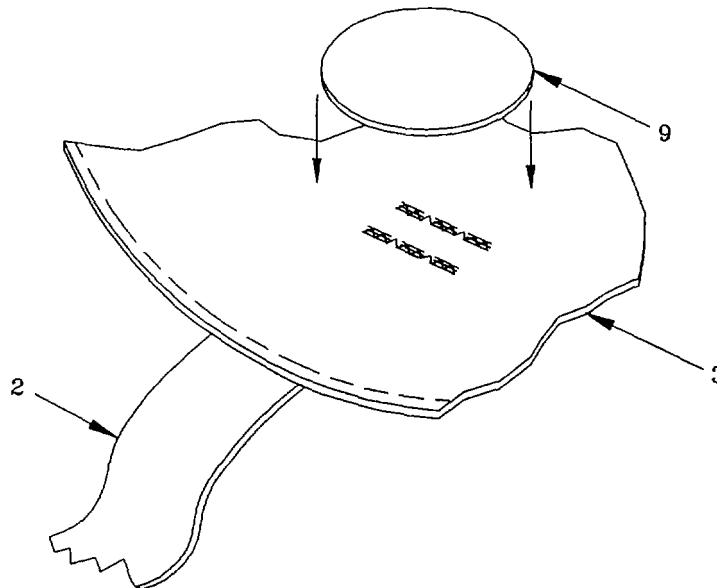
**WARNING**

Use maintenance kit adhesive in a well ventilated area only and avoid skin contact. Wear proper protective equipment. Failure to do so may result in light-headedness or a burning sensation to the eyes and skin. In case of skin contact, wash with soap and water. If vapors become strong, leave the area and allow to ventilate.

- (b) Apply a coating of adhesive (4) to the strap (2) and allow the cemented area to become tacky to the touch.
- (c) Fold strap (2) in half and roll strap with hand roller (5).



- (3) Install buckles (6) and (7) on strap (2) and sew as required.
- (4) Install snap fasteners (8) IAW paragraph 5-11 or FM 10-16.



- (5) Sew the new strap (2) to the hood (3), making sure that the thread ends are stitched or cross-stitched.
- (6) Clean stitched area with isopropyl alcohol and abrasive strip.
- (7) Apply a cemented patch (9) on the inside of the hood (3) to cover the stitching. Apply a second, cemented patch (9) to the outside of the hood (3) at the stitching.
- (8) Apply a light coat of powdered talc to both sides of the patched area to prevent them from adhering to other portions of the hood.

5-13. M2A1 TAP BOOTS

This task covers:

- a. **Inspect M2A1 TAP Boots**
- b. **Leak Testing M2A1 TAP Boots**

INITIAL SETUPTools:

Air Leakage Tester, Q79A1 (Appendix B, Section III, Item 1)
 Tank, Electrically Heated (Appendix B, Section III, Item 7)

Materials/Parts:

Ink Pad, Rubber Stamp (Appendix F, Item 11)
 Ink, Stencil (Appendix F, Item 12)
 Chalk, White (Appendix F, Item 1)
 Stencil Roller (Appendix F, Item 18)

Equipment Condition:

Boots must be clean and decontaminated.

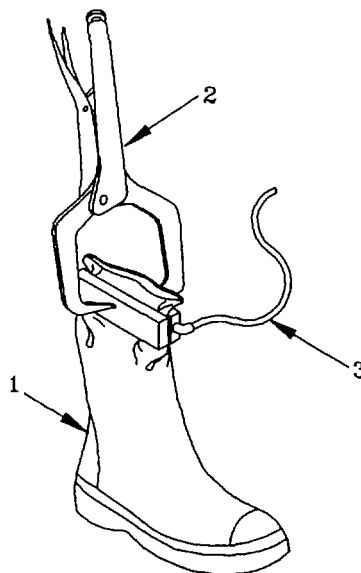
a. Inspect. Inspect boot in accordance with procedures outlined in Table 2-1. Use Equipment Inspection and Maintenance Worksheet DA Form 2404 to record all defects found. If inspection reveals a condition that renders a boot unserviceable, turn-in IAW local SOP.

b. Test.

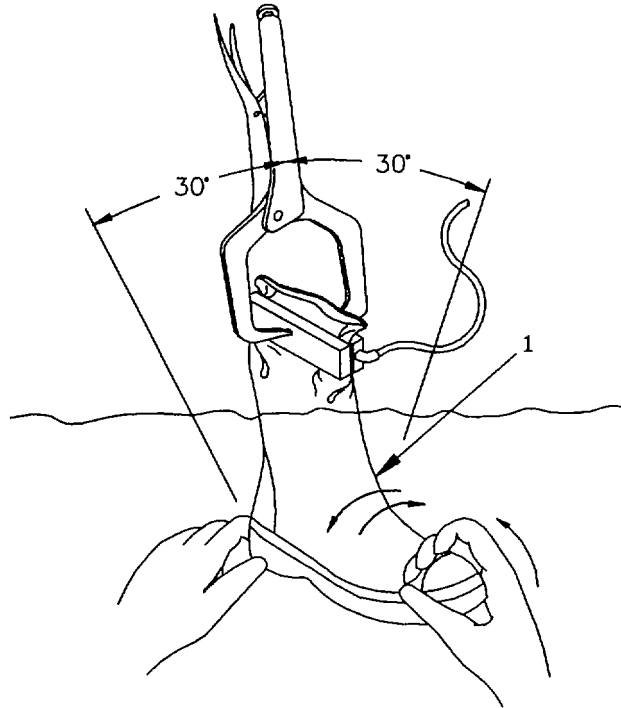
NOTE

**Pause at each observation point no less than 10 seconds.
 Visible bubbling at any point during the test is not acceptable,
 excluding bubbles caused by surface trapped air.**

- (1) Seal the top of the boot (1) with an air pressure clamp (2), by placing the boot material flat between the clamp plates.



- (2) Connect the test hose (3) to the nipple on the air pressure clamp (2).
- (3) Inflate boot to 0.5 0.6 psi.



- (4) Immerse boot (1) vertically in about 14 inches of water. Observe for air leaks indicated by a stream of air bubbles escaping from the source of the leak.
- (5) Tilt boot (1) approximately 30° to the left.
- (6) Grasp heel in one hand and the toe in the other and perform the following steps:
 - a Flex the sole. Observe for leaks.
 - b Twist boot (1) clockwise. Observe for leaks.
 - c Twist boot (1) counterclockwise. Observe for leaks.
- (7) Tilt boot (1) approximately 30° to the right and repeat step (6).
- (8) If leakage test indicates a leak anywhere in the boot, turn-in IAW local SOP.
- (9) If boot passes leakage test, stencil next inspection due date.

5-14. M3 TAP COVERALLS.

This task covers:

- a. **Inspect M3 TAP Coveralls**
- b. **Test M3 TAP Coveralls**
- c. **Repair Stitching**
- d. **Repair Coverall Material**
- e. **Repair Strapping and Tunnels**
- f. **Replace Snap Fasteners**
- g. **Replace Webbing and Buckles**

INITIAL SETUPTools:

Air Leakage Tester, Q79A1 (Appendix B, Section III, Item 1)
 Brush, Paint, 3.5 inch (Appendix F, Item 6)
 Maintenance Kit (Appendix B, Section III, Item 2)
 Roller, Hand (Appendix F, Item 16)
 Sewing Machine (Appendix B, Section III, Item 4)

Materials/Parts:

Adhesive, Caroline (Appendix F, Item 3)
 Buckle (Appendix C-2, Item 1)
 Chalk, White (Appendix F, Item 1)
 GERAPON T77 (Appendix F, Item 6)
 Ink Pad, Rubber Stamp (Appendix F, Item 11)
 Ink, Stencil (Appendix F, Item 12)
 Snap Fastener (Appendix C-2, Item 2)
 Snap Fastener (Appendix C-2, Item 5)
 Stencil Roller (Appendix F, Item 18)
 Talc, Tech (Appendix F, Item 21)
 Thread, Polyester (Appendix C-2, Item 4)
 Toluene (Appendix F, Item 23)
 Webbing, 3/4 inch (Appendix C-2, Item 3)

Equipment Condition:

Coveralls must be clean and decontaminated.

a. Inspect M3 TAP Coveralls.

(1) *General Inspection Criteria.* A minimum of 150 foot candles of uniform illumination is required at the inspection surface. Inspections must be done with the naked eye. Any defects noted can be more closely examined with magnification no greater than 10X. The number of patches allowed per serviceable coverall shall be 20, with a maximum of 8 per panel. Only patches on the outside of the coverall in critical areas will be counted towards the 20-patch maximum allowance. Non-critical areas of the coverall are sleeve and leg edges, top of the neck area covered by the hood, belt, and gusset. Standard inspection procedures include an initial visual examination utilizing the following method. Record inspection results on DA Form 2404. If inspection reveals a condition that renders the coveralls unserviceable, turn-in IAW local SOP.

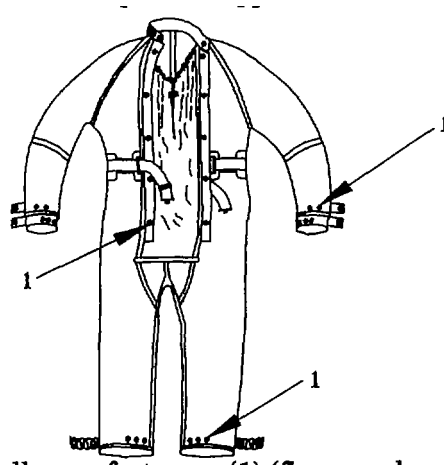
CAUTION

Remove all jewelry and long finger nails prior to handling TAP Ensemble components. Failure to do so may result in damage to TAP Ensemble components.

(2) *Inspection.*

(a) Inspection of Snap Fasteners.

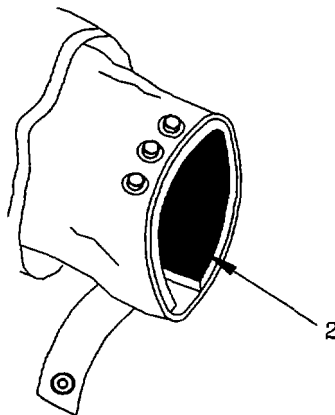
1. Remove coveralls from unit pack (if applicable).



2. Snap and unsnap all snap fasteners (1) (five per sleeve and three per leg, for a total of 16 fasteners) twice, to ensure secure closure and free separation.
3. Mark any fastener that malfunctions, is missing, reversed on assembly, improperly affixed, or is misshapen with chalk.
4. Turn coverall inside out.

(b) Inspection of left and right sleeves (inside).

1. Inspect for cuts, holes, tears, which extends through the coating exposing the fabric. Inspect for uncoated areas, pits, blisters, tunnels or delamination of coating. Inspect for protruding lumps or embedded foreign matter which could be readily abraded from material or easily removed. Inspect for creases or wrinkles, resulting in adhesion of surface or delamination of coating when corrected by manual pressure.
2. Inspect all strapping for looseness or tunnels. Probe any suspected tunnel with probing device. Ensure strapping completely covers stitching. Ensure continuous length of strapping that covers each individual seam. Ensure ends of strapping which meet are overlapped.

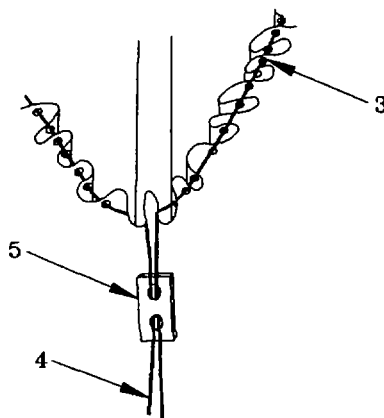


3. Inspect sponge pad (2) to ensure that it is cemented securely.
4. Mark any defects with chalk.

5-14. M3 TAP COVERALLS. (CONT)

- (c) Inspection of back top half (inside). Repeat steps (b) 1, (b) 2, and (b) 4.
- (d) Inspection of front top half (inside).

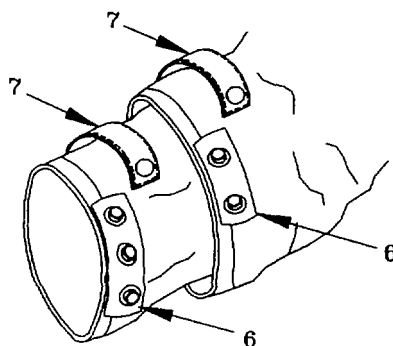
1. Examine gusset and strapping using procedures (b) 1 and (b) 2.



2. Examine 22 eyelets (3) to ensure secure attachment.
3. Examine gusset reinforcement piece to ensure secure attachment with no open seams.
4. Ensure gusset cord (4) and cord lock (5) are present and functioning.
5. Mark all defects with chalk.

- (e) Inspection of lower gusset/crotch area (inside). Examine by using procedures (b) 1, (b) 2. and (b) 4.
- (f) Inspection of right and left leg (inside). Examine by using procedures (b) 1, (b) 2 and (b) 4.
- (g) Reverse coverall right side out.
- (h) Ensure suspenders are present, secure and adjustable.
- (i) Inspection of right and left sleeve (outside).

1. Examine by using procedures (b) 1 and (b) 2.



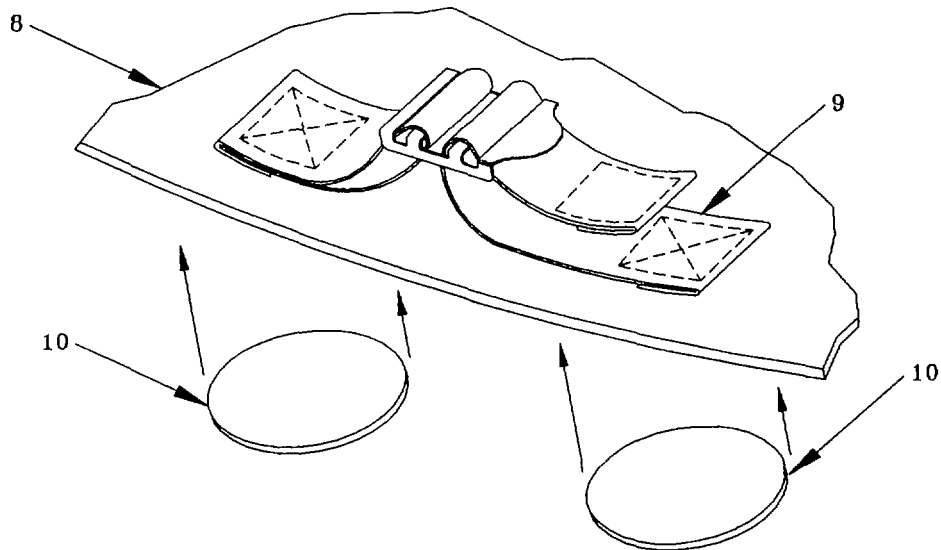
2. Ensure snap fastener reinforcement patches (6) are secure along all edges.
3. Ensure sleeve tabs (7) are secure, with female portion of snap fastener facing male portion.
4. Turn outer sleeve inside out and examine strapping to ensure it is attached securely along the edges.
5. Mark all defects with chalk.

(j) Inspection of right and left front upper half (outside).

1. Repeat steps (b) 1 and (b) 2.
2. Ensure facings are not tight, short, or twisted, resulting in puckering or distortion.
3. Mark all defects with chalk.

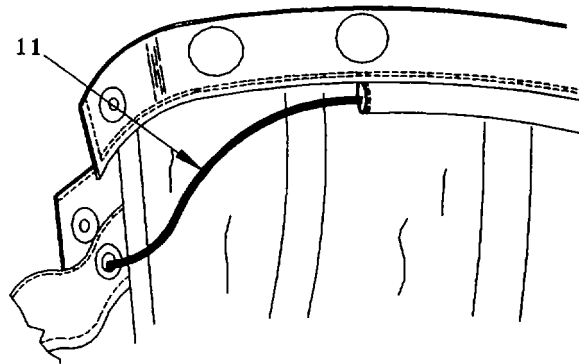
(k) Inspection of gusset (outside). Repeat steps (b) 1, (b) 2 and (b) 4.

(l) Inspection of collar (inside and outside).



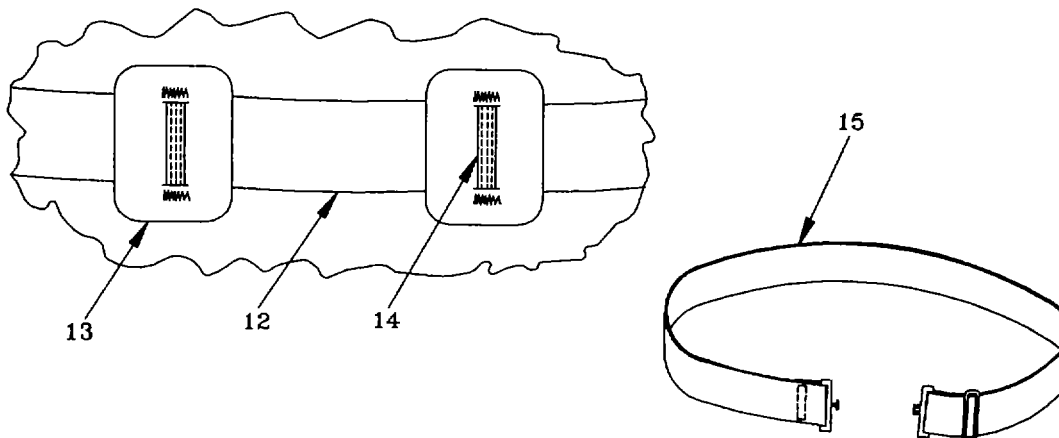
1. Ensure collar (8) is not twisted, puckered, or pleated at the joints of front and back panels to collar.
2. Ensure webbing straps (9) are attached with box stitch.
3. Ensure reinforcement patches (10) are attached securely.

5-14. M3 TAP COVERALLS. (CONT)



4. Ensure neck drawcord (11) loop is securely stitched to underside of collar.
5. Mark all defects with chalk.

- (m) Inspection of back upper half (outside). Examine both left and right halves using procedures (b) 1, (b) 2 and (b) 4.
- (n) Inspection of waistband (outside).



1. Ensure waistband (12) is secure along all edges.
2. Ensure belt loop reinforcement patches (13) are secure.
3. Ensure all six belt loops (14) are attached securely.
4. Ensure belt (15) is included.
5. Ensure overlapped edges of belt (15) are secure.
6. Mark all defects with chalk.

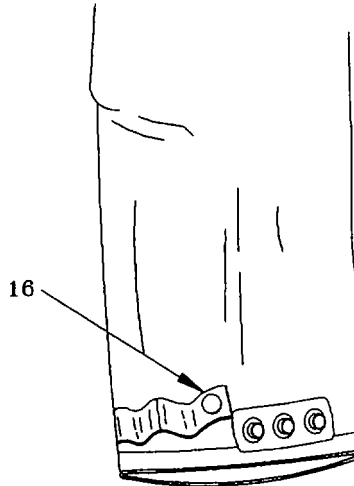
(o) Inspection of front lower half, including lower gusset and crotch area (outside).

1. Repeat steps (b) 1 and (b) 2.
2. Ensure crotch reinforcement pad is present and all edges are secure.
3. Mark all defects with chalk.

(p) Inspection of back lower half (outside). Repeat steps (b) 1 (b) 2, and (b) 4.

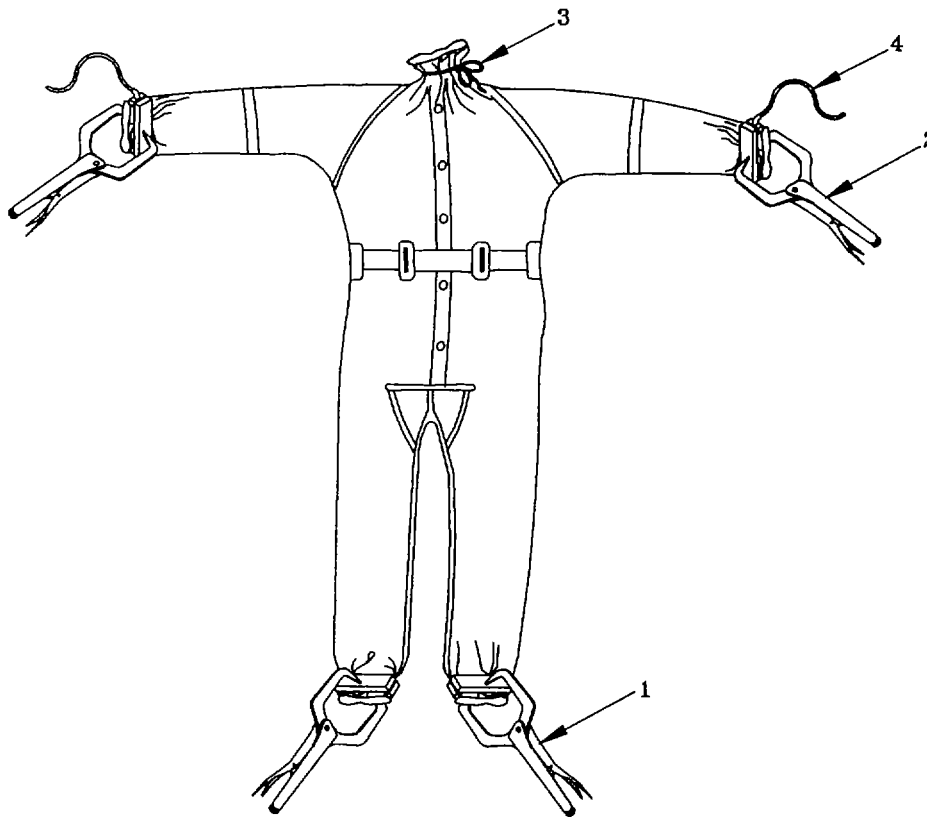
(q) Inspection of right and left legs (outside).

1. Repeat steps b.(1) and b.(2).



2. Examine leg adjusting strap (16) to ensure elastic piece is present and it has been attached with a box stitch. The female portion of snap fastener on the leg adjusting strap should be faced away from male portion of the snaps.
3. Ensure edges of reinforcement patches are secure.
4. Mark all defects with chalk.

5-14. M3 TAP COVERALLS. (CONT)

b. Test M3 TAP Coveralls.

- (1) Block leg openings with padded seal clamps (1), by placing coverall material flat between the clamp plates.
- (2) Block wrist openings with padded air pressure clamps (2), by placing coverall material flat between the clamp plates.
- (3) Gather neck closure below the drawstring and secure using a spare drawstring (3) or similar tie that will not damage coverall.
- (4) Connect the leakage tester air supply hose (4) to the nipple of one air pressure clamp (2) and the test hose (4) to the nipple of the other air pressure clamp (2).
- (5) Inflate the coverall to a pressure of 3.5 ± 0.5 cm H₂O. Maintain that pressure.
- (6) Prepare a 2.5% by weight solution of GERAPON T77 by mixing 3.2 oz. (100 grams) of GERAPON T77 per 1 gal. of water.
- (7) Progressively brush the coverall with solution and watch for the appearance of bubbles

that indicates a leak at the point of observation. Cover entire exposed surface of coveralls. Mark suspected leaks with chalk.

- (8) Turn the coveralls over and repeat step (7).
- (9) When test is complete, rinse coveralls completely with clean water to remove all solution.
- (10) Deflate coveralls and remove all clamps and drawstring.
- (11) Hang coveralls to dry.
- (12) If the leakage test indicates leaks that can not be patched, turn-in IAW local SOP.
- (13) If coveralls pass test, stencil with next inspection due date.

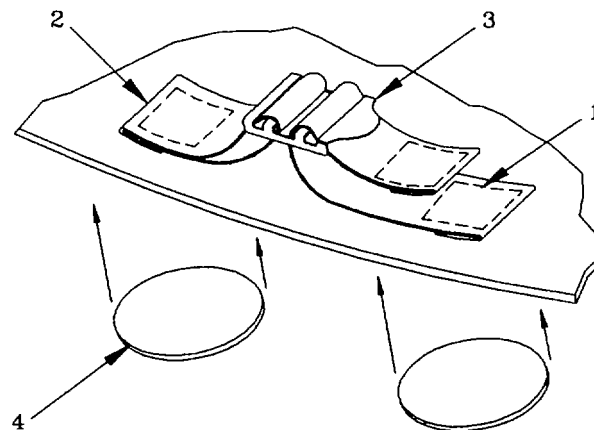
c. Repair Stitching. Repair stitching IAW procedures in paragraph 5-8. All stitching shall be Type 301, with 8 10 stitches per inch. See paragraph 5-8.

d. Repair Coverall Material. No more than 20 patches total or 8 per panel may be applied to the outside of coveralls. Make repairs IAW paragraph 5-9.

e. Repair Strapping and Tunnels. Repair strapping and tunnels IAW paragraph 5-10.

f. Replace Snap Fasteners. Replace snap fasteners IAW paragraph 5-11.

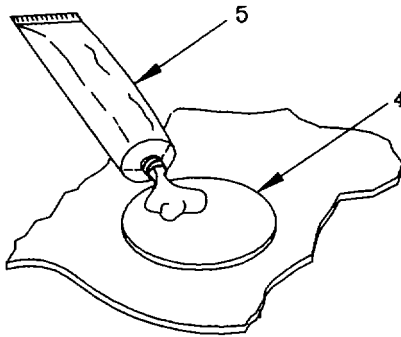
g. Replace Webbing and Buckles.



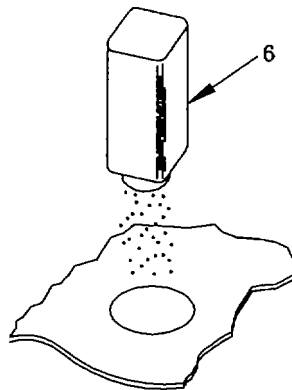
- (1) Remove the stitching (1) that secures the strap (2) to garment, and remove strap (2).

5-14. M3 TAP COVERALLS. (CONT)

- (2) Obtain a strap (2) from salvage, or fabricate one as follows:
 - (a) Measure an undamaged strap (2) (to include folds and turn-unders) and cut a length from the webbing bulk stock or salvaged material (also see Appendix G, List of Manufactured Items).
 - (b) Install new buckle (3) on the strap and sew where required.
- (3) Position strap (2) on coveralls and sew.



- (4) Cement a patch (4) over the stitching on inside of coveralls and allow to set.
- (5) Apply adhesive (5) over the patched area and allow it to become tacky.



- (6) Sprinkle powdered talc (6) on adhesive to prevent adhesion to other parts of the garment.

5-15. M1 TAP FOOTWEAR COVERS

This task covers:

- a. **Inspect M1 TAP Footwear Covers**
- b. **Repair MI TAP Footwear Cover Material**

INITIAL SETUPTools:

Maintenance Kit (Appendix B, Section III, Item 2)

Materials/Parts:

Ink Pad (Appendix F, Item 11)

Ink, Stencil (Appendix F, Item 12)

Chalk, White (Appendix F, Item 1)

Stencil Roller (Appendix F, Item 18)

Equipment Condition:

Footwear covers must be clean and decontaminated.

a. Inspect. Inspect footwear covers in accordance with procedures outlined in Table 2-1. Use Equipment Inspection and Maintenance Worksheet DA Form 2404 to record all defects found. The maximum number of patches allowed on the inside or outside of the footwear covers is 4. If inspection reveals a condition that would render the footwear covers unserviceable, turn-in IAW local SOP, otherwise, stencil footwear covers with next inspection due date.

NOTE

Soles of M1 TAP Footwear Covers shall not be patched.

b. Repair Footwear Cover Material. No more than 4 patches may be applied to the inside or outside of the footwear covers. Make repairs IAW paragraph 5-9.

5-16. M3/M4 TAP GLOVES.

This task covers:

- a. **Inspect M3/M4 TAP Gloves**
- b. **Test M3/M4 TAP Gloves**

INITIAL SETUP

Tools:

Air Leakage Tester, Q79A1 (Appendix B, Item 1)
 Tank, Electrically Heated (Appendix B, Item 9)

Materials/Parts:

Ink Pad, Rubber Stamp (Appendix F, Item 11)
 Ink, Stencil (Appendix F, Item 12)
 Chalk, White (Appendix F, Item 1)
 Stencil Roller (Appendix F, Item 18)

Equipment Condition:

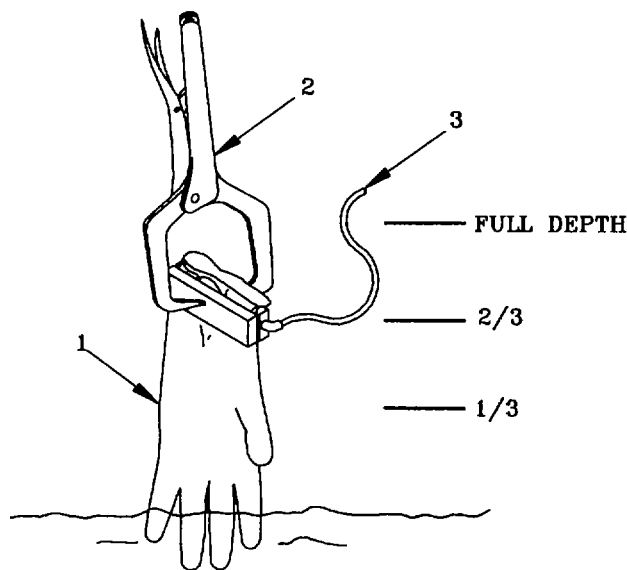
Gloves must be clean and decontaminated.

a. Inspect. Inspect gloves in accordance with procedures outlined in Table 2-1. Use Equipment Inspection and Maintenance Worksheet DA Form 2404 to record all defects found. If inspection reveals a condition that would render the gloves unserviceable, turn-in IAW local SOP.

b. Test.

NOTE

- **Do not immerse glove below a 6 inch depth. Water pressure below 6 inches can be great enough to prevent release of air bubbles from a small hole or tear.**
- **Visible bubbling is not acceptable at any point during the test.**



- (1) Seal the glove (1) with an air pressure clamp (2), by placing the material around the wrist flat between the clamp plates.
- (2) Connect test hose (3) to nipple on air pressure clamp (2)
- (3) Pressurize glove to 0.5 ± 0.25 psig.
- (4) Immerse gloves (1) fingers first, to a point where 1/3 of the glove is submerged. Carefully observe for air bubbles.
- (5) Lower until glove (1) is 2/3 submerged. Carefully observe for air bubbles.
- (6) Immerse remainder of glove (1) submerging the cuff bead no lower than 1 inch below the water line. Carefully observe for air bubbles.
- (7) If leakage test indicates a leak anywhere in the glove, turn-in IAW local SOP.
- (8) If glove passes test, stencil with next inspection due date.

5-17. M2 TAP APRON.

This task covers:

- a. **Inspect M2 TAP Apron**
- b. **Repair Stitching**
- c. **Repair M2 TAP Apron Material**
- d. **Repair Strapping and Tunnels**
- e. **Replace Webbing and Buckles**

INITIAL SETUPTools:

Maintenance Kit (Appendix B, Section III, Item 2)

Sewing Machine (Appendix B, Section III, Item 5)

Materials/Parts:

Adhesive, Caroline (Appendix F, Item 3)

Buckle, 5/8 inch (Appendix C-3, Item 2)

Chalk, White (Appendix F, Item 1)

Fastener, Quick Release (Appendix C-3, Item 1)

Ink Pad (Appendix F, Item 11)

Ink, Stencil (Appendix F, Item 12)

Roller, Hand (Appendix B, Item 16)

Stencil Roller (Appendix F, Item 18)

Thread, Polyester (Appendix C-3, Item 5)

Talc, Tech (Appendix F, Item 21)

Equipment Condition:

Apron must be clean and decontaminated.

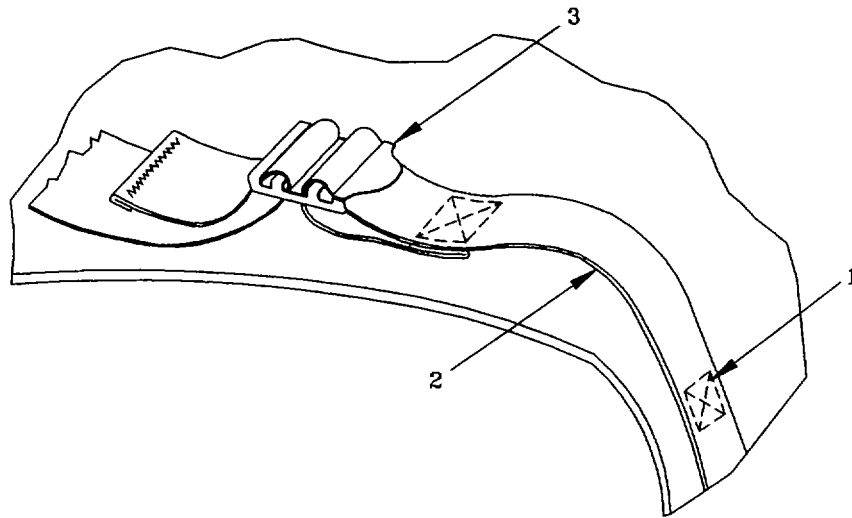
a. Inspect. Inspect apron in accordance with procedures outlined in Table 2-1. Use Equipment Inspection and Maintenance Worksheet DA Form 2404 to record all defects found. The maximum number of patches allowed is 10 per section for each section of apron. If inspection reveals a condition that renders the apron unserviceable, turn-in IAW local SOP, otherwise, stencil with next inspection due date.

b. Repair Stitching. Repair stitching IAW procedures in paragraph 5-8. All stitching shall be Type 301, with 8 10 stitches per inch. See paragraph 5-8.

c. Repair Apron Material. No more than 10 patches may be applied to the any section of the apron. Make repairs IAW paragraph 5-9.

d. Repair Strapping and Tunnels. Repair strapping and tunnels IAW paragraph 5-10.

e. Replace Webbing and Buckles.



(1) Remove the stitching (1) that secures the straps (2) to the garment, and remove the straps (2).

(2) Obtain a strap (2) from salvage, or fabricate one as follows:

(a) Measure an undamaged strap (2) (to include folds and turn-unders) and cut a length from the webbing bulk stock (also see Appendix G, Illustrated List of Manufactured Items).

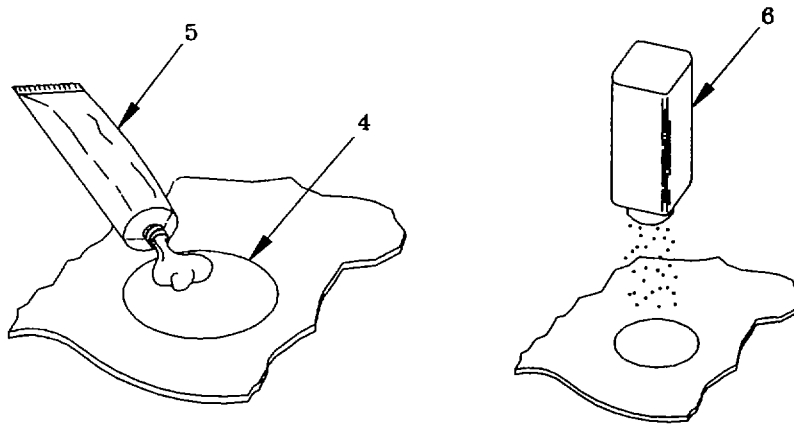
(b) Install new buckle or fastener (3) on the straps (2) and sew where required.

(3) Position strap (2) on the apron and sew.

5-17. M2 TAP APRON. (CONT)

WARNING

Use maintenance kit adhesive in a well ventilated area only and avoid skin contact. Failure to do so may result in light-headedness or a burning sensation to the eyes and skin. In case of skin contact, wash with soap and water. If vapors become strong, leave the area and allow to ventilate.



- (4) Cement a patch (4) over the stitching on the inside of the apron and allow to set.
- (5) Apply adhesive (5) over the patched area and allow it to become tacky.
- (6) Sprinkle powdered talc (6) on the adhesive to prevent adhesion to other parts of the apron.

5-18. LAUNDERING TIE CHEMICAL PROTECTIVE CLOTHING OUTFIT

This task covers:

- a. Machine/Hand Laundering
- b. Drying
- c. Marking

INITIAL SETUP**NOTE**

Clothing Outfits worn in a contaminated environment will be laundered in accordance with DA Pam 385-61.

Tools:

None

Materials/Parts:

Detergent (Appendix F, Item 11)

Chalk, White (Appendix F, Item 1)

Marker, Felt Tip (Appendix F, Item 13)

Equipment Condition: N/A

a. **General.** The Chemical Protective Clothing Outfit must be laundered after each use. It may be laundered up to six times before reimpregnating allowing a total of 7 wearings (initial use and six launderings/wearings) prior to turn-in for reimpregnating.

CAUTION

Do NOT use bleach or starch on clothing outfit. Never press or dry clean. Chemical protection capacity of the clothing outfit may be degraded.

b. **Machine/Hand Laundering.** Use permanent press wash cycle or hand wash using warm water (90°-100°F/32°-38°C) and mild laundry detergent (non-phosphate).

c. **Drying.** Tumble dry at low temperatures (110°-120°F/43°-49°C) and remove immediately from dryer. To drip dry, remove from water and place on rust-proof hanger.

d. **Marking Procedures.** Each item must be marked after drying to indicate number of launderings it has undergone. Mark with a numerical character using a felt tip marker in the following locations:

- (1) *Shirt.* Mark outside area of interior button flap, between buttons.
- (2) *Trousers.* Mark outside area of interior button flap, below buttons.
- (3) *Socks.* Mark outside upper portions, above ankles.
- (4) *Gloves.* Mark outside gauntlet area.

5-18. LAUNDERING TEE CHEMICAL PROTECTIVE CLOTHING OUTFIT. (CONT)

WARNING

FIRE HAZARD. Ensure chemical protective clothing is completely dry before packaging. Compressing chemical protective clothing while damp can cause spontaneous combustion. Failure to observe this warning may result in severe injury or death.

- e. Storage. After drying, place in clothing outfit bag.

APPENDIX A

REFERENCES

SCOPE. This appendix lists all forms, military specifications, field manuals, and technical manuals referenced in this manual.

FEDERAL STANDARDS

Stitches, Seams and Stitching FED-STD-751

FORMS

Packaging Improvement Report DD Form 6
 Equipment Inspection and Maintenance Worksheet DA Form 2404
 Equipment Modification Record DA Form 2408-5
 Product Quality Deficiency Report SF-368
 Recommended Changes to Publications DA Form 2028
 Recommended Changes to Equipment Technical Manuals DA Form 2028-2

FIELD MANUALS

NBC Contamination Avoidance FM 3-3
 NBC Decontamination FM 3-5
 General Fabric Repair FM 10-16

MILITARY STANDARDS

Sampling Procedures and Tables for Inspection by Attributes MILSTD-105
 Palletized Unit Loads MILSTD-147

PAMPHLETS

Consolidated Index of Army Publications and Blank Forms DA PAM 25-30
 Toxic Chemical Agent Safety Standards DA PAM 385-61
 The Army Maintenance Management System (TAMMS)
 Maintenance Management Update DA PAM 738-750

REGULATIONS

The Army Toxic Chemical Agent Safety Program AR 385-61

SPECIFICATIONS

Boxes, Shipping and Fiberboard PPP-B-636

TECHNICAL MANUALS

Destruction of Army Materiel to Prevent Enemy Use TM 750-244-3
 Operator's Manual for Chemical-Biological Mask: Field M40 TM 3-4240-300-10-1
 Operator's, Unit, Direct Support, and General Support Maintenance Manual for Mask; Chemical Biological, Special Purpose,
 M9 & M9A1 & Associated Accessories TM 3-4240-204-14
 Operator's Manual for Mask; Chemical-Biological, Field
 M17, M17A1, M17A2 and Associated Accessories TM 3-4240-279-10
 Packaging of Materials TM 38-230-2
 Chemical/Biological (C/B), and Related Materials;
 Characteristics, Leak Sealing, Disposal and Decontamination TM 60A-1-1-11
 General Repair Procedures for Clothing TM 10-8400-201-23
 General Repair Procedures for Individual Equipment TM 10-8400-203-23

APPENDIX B

MAINTENANCE ALLOCATION CHART (MAC)

Section I. INTRODUCTION

B-1. THE ARMY MAINTENANCE SYSTEM MAC.

a. This introduction (Section I) provides a general explanation of all maintenance and repair functions authorized at various maintenance levels under the Standard Army Maintenance System concept.

b. The Maintenance Allocation Chart (MAC) in Section II designates overall authority and responsibility for the performance of maintenance functions on the identified end item or component. The application of the maintenance functions to the end item or component will be consistent with the capacities and capabilities of the designated maintenance levels, which are shown on the MAC in column (4) as:

Unit - includes two sub-columns, C (operator/crew) and 0 (unit) maintenance.

Direct Support - includes an F sub-column.

General Support - includes an H sub-column.

Depot - includes a D sub-column.

c. Section III lists the tools and test equipment (both special tools and common tool sets) required for each maintenance function as referenced from Section II.

d. Section IV contains supplemental instructions and explanatory notes for a particular maintenance function.

B-2. MAINTENANCE FUNCTIONS . Maintenance functions are limited to and defined as follows:

a. Inspect. To determine the serviceability of an item by comparing its physical, mechanical and/or electrical characteristics with established standards through examination (e.g. by sight, sound, or feel).

b. Test. To verify serviceability by measuring the mechanical, pneumatic, hydraulic, or electrical characteristics of an item and comparing those characteristics with prescribed standards.

c. Service. Operations required periodically to keep an item in proper operating condition: e.g. to clean (includes decontaminate, when required), to preserve, to drain, to paint, or to replenish fuel, lubricants, chemical fluids, or gases.

d. Adjust. To maintain or regulate, within prescribed limits, by bringing into proper position, or by setting the operating characteristics to specified parameters.

e. Align. To adjust specified variable elements of an item to bring about optimum or desired performance.

B-2. MAINTENANCE FUNCTIONS (CONT).

f. Calibrate. To determine and cause corrections to be made or to be adjusted on instruments or test, measuring, and diagnostic equipments used in precision measurement. Consists of comparisons of two instruments, one of which is a certified standard of known accuracy, to detect and adjust any discrepancy in the accuracy of the instrument being compared.

g. Remove/Install. To remove and install the same item when required to perform service or other maintenance functions. Install may be the act of emplacing, seating, or fixing into position a spare, repair part, or module (component or assembly) in a manner to allow the proper functioning of an equipment or system.

h. Replace. To remove an unserviceable item and install a serviceable counterpart in its place. "Replace" is authorized by the MAC and assigned maintenance level is shown as the 3d position code of the SMR code.

i. Repair. The application of maintenance services including fault location/troubleshooting², removal/installation, and disassembly/assembly⁴ procedures, and maintenance actions to restore serviceability to an item by correcting specific damage, fault, malfunction, or failure in a part, subassembly, module (component or assembly), end item, or system.

j. Overhaul. That maintenance effort (service/action) prescribed to restore an item to a completely serviceable/operational condition as required by maintenance standards in appropriate technical publications (i.e., DMWR). Overhaul is normally the highest degree of maintenance performed by the Army. Overhaul does not normally return an item to like new condition.

k. Rebuild. Consists of those service/actions necessary for the restoration of unserviceable equipment to a like new condition in accordance with original manufacturing standards. Rebuild is the highest degree of materiel maintenance applied to Army equipment. The rebuild operation includes the act of returning to zero those age measurements (e.g. hours, miles) considered in classifying Army equipments/components.

B-3. EXPLANATION OF COLUMNS IN THE MAC, SECTION HI.

a. Column 1, Group Number. Column 1 lists functional group code numbers, the purpose of which is to identify maintenance significant components, assemblies, subassemblies, and modules with the next higher assembly.

b. Column 2, Component/Assembly. Column 2 contains the item names of components, assemblies, subassemblies, and modules for which maintenance is authorized.

c. Column 3, Maintenance Functions. Column 3 lists the functions to be performed on the

1 Services Inspect, test, service, adjust, align, calibrate, and/or replace.

2 Fault location/troubleshooting The process of investigating and detecting the cause of equipment malfunctioning, the act of isolating a fault within a system or unit under test (UUT).

3 Disassembly/assembly The step-by-step breakdown (taking apart) of a spare/functional group coded item to the level of its least component, that is assigned an SMR code for the level of maintenance under consideration (i.e., identified as maintenance significant).

4 Actions Welding, grinding, riveting, straightening, facing, machining, and/or resurfacing.

item listed in Column 2. (For detailed explanation of these functions, see paragraph B-2.)

d. Column 4, Maintenance Level. Column 4 specifies each level of maintenance authorized to perform each function listed in Column 3, by indicating work time required (expressed as man-hours in whole hours or decimals) in the appropriate sub-column. This work-time figure represents the active time required to perform that maintenance function at the indicated level of maintenance. If the number or complexity of the tasks within the listed maintenance function vary at different maintenance levels, appropriate work-time figures are to be shown for each level. The work-time figure represents the average time required to restore an item (assembly, subassembly, component, module, end item or system) to a serviceable condition under typical field operating conditions. This time includes preparation time (including any necessary disassembly/assembly time), troubleshooting/fault location time, and quality assurance time in addition to the time required to perform the specific tasks identified for the maintenance functions authorized in the maintenance allocation chart. The symbol designations for the various maintenance levels are as follows:

- COperator or crew maintenance
- OUnit maintenance
- F.....Direct support maintenance
- L.....Specialized Repair Activity (SRA)5
- HGeneral support maintenance
- DDepot maintenance

e. Column 5, Tools and Test Equipment Reference Code. Column 5 specifies, by code, those common tool sets (not individual tools), common TMDE, and special tools, special TMDE, and special support equipment required to perform the designated function. Codes are keyed to tools and test equipment in Section III.

f. Column 6, Remarks. When applicable, this column contains a letter code, in alphabetical order, which is keyed to the remarks contained in Section IV.

B-4. EXPLANATION OF COLUMNS IN TOOL AND TEST EQUIPMENT REQUIREMENTS, SECTION III.

a. Column 1, Reference Code. The tool and test equipment reference code corresponds with a code used in the MAC, Section II, Column 5.

b. Column 2, Maintenance Level. The lowest level of maintenance authorized to use the tool or test equipment.

c. Column 3, Nomenclature. Name or identification of the tools or test equipment.

d. Column 4, National Stock Number. The National Stock Number of the tool or test equipment.

e. Column 5, Tool Number. The manufacturer's part number, model number, or type number.

5. This maintenance level is not included in Section II, column (4) of the Maintenance Allocation Chart. Functions to this level of maintenance are identified by a work-time figure in the "H" column of Section II, column (4), and an associated reference code used in the Remarks column (6). This code is keyed to Section IV, Remarks, and the SRA complete repair application is explained there.

B-5. EXPLANATION OF COLUMNS IN REMARKS, SECTION IV.

- a. Column 1, Remarks Code. The code recorded in column 6, Section II.
- b. Column 2, Remarks. This column lists information pertinent to the maintenance function being performed as indicated in the MAC, Section II.

**Section II. MAINTENANCE ALLOCATION CHART
FOR
TOXICOLOGICAL AGENT PROTECTIVE (TAP) ENSEMBLE**

(1) Group Number	(2) Component/ Assembly	(3) Maintenance Function	(4) Maintenance Level					(5) Tools and Equipment	(6) Remarks
			C	O	F	H	D		
00	Toxicological Agent Protective (TAP) Ensemble								A
01	Hoods, Toxicological Agent Protective, M3 & M40 Special Purpose	Inspect Service Repair	.25 25	1.0	.25			2,3,4,5	B,C
02	Boots, Toxicological Agent Protective, M2A1 Test Service	Inspect	.25		.25 .25 .25			1,7	
03	Coveralls, Toxicological Agent Protective, M3 Service Repair	Inspect Test	.25		.75 .50 .25 1.0			1 2,3,4,5,6	
04	Footwear Cover, Toxicological Agents Protective, MI	Inspect Service Repair	.25		.25 .25 1.0			2,3	
05	Gloves, Toxicological Agent Protective, M3/M4	Inspect Test Service	.25		.25 .25 .25			1,7	
06	Apron, Toxicological Agent Protective, M2	Inspect Service Repair	.25		.25 .25 1.0			2,3,4	
07	Clothing Outfit, (Impregnated Set)	Inspect Service	.25		.25 .25				D

**Section III. TOOLS AND TEST EQUIPMENT
FOR
TOXICOLOGICAL AGENT PROTECTIVE (TAP) ENSEMBLE**

(1) Tool or Test Equipment Ref Code	(2) Maintenance Level	(3) Nomenclature	(4) National Stock Number	(5) Tool Number
1	F	AIR LEAKAGE TESTER, Q79A1 (81861)136-45-320	6665-01-082-1111	
2	F	MAINTENANCE KIT, TOXICOLOGICAL AGENT PROTECTIVE CLOTHING, BUTYL RUBBER COATED, MIL-M41837	841-00-889-3654	
3	F	ROLLER, HAND	5120-00-243-9401	
4	F	SEWING MACHINE, INDUSTRIAL	3530-00-8924631	
5	F	SNAP SETING TOOL (77681) HA-80		
6	F	SNAP SET[ING TOOL (77681) HA-95		
7	F	TANK, ELECTRICALLY HEATED WIENCLOSED HEAT STRIP (RANGE TO 180° (82°C)		

**Section IV REMARKS
FOR
TOXICOLOGICAL AGENT PROTECTIVE (TAP) ENSEMBLE**

Remarks Code	Remarks
A	There are no maintenance time allocations for a "generic" ensemble. Combinations of different individually listed clothing items make up more than one TAP Ensemble. Refer to functional groups 01 through 07 for detailed information.
B	Functional group includes the following: (a) Hood, Gas Mask, Toxicological Agent Protective (TAP), M3; (b) Hood, Gas Mask, Special Purpose, Toxicological Agent Protective (TAP), M3A1; (c) Hood, Chemical-Bio, M6A2 (for M17 Series Masks); (d) Hood, Chemical-Biological (for M40 Standard Mode Mask). All TAP items require quarterly inspection when used with the TAP ensemble.
C	For all maintenance of Hood, Chemical-Biological, M6A2 and Hood, Chemical-Biological M40 General Purpose, see TM 10-4240-279-10 and TM 10-4240-300-10-1.
D	Clothing Outfit should be used as required to conform with protection levels specified in DA PAM 385-61 and AR 385-61.

APPENDIX C

OPERATOR, UNIT, AND
DIRECT SUPPORT MAINTENANCE
REPAIR PARTS AND SPECIAL TOOLS LIST

Section I. INTRODUCTION

C-1. SCOPE. This Repair Parts and Special Tools List (RPSTL) lists and authorizes spares and repair parts; special tools; special Test, Measurement, and Diagnostic Equipment (TMDE); and other special support equipment required for performance of operator, unit, and direct support maintenance of the Toxicological Agent Protective (TAP) Ensemble. It authorizes the requisition, issue, and disposition of spares, repair parts, and special tools as indicated by the Source, Maintenance, and Recoverability (SMR) codes.

C-2. GENERAL. In addition to Section I, Introduction, this RPSTL is divided into the following sections:

a. Section II Repair Parts List. A list of spares and repair parts authorized by this RPSTL for use in the performance of maintenance. The list also includes parts that must be removed for replacement of the authorized parts. Parts lists are composed of functional groups in ascending alphanumeric sequence, with the parts in each group listed in ascending figure and item number sequence. Bulk materials are listed by name in FIG BULK at the end of the section. Repair parts kits or sets are listed separately in their own functional group within Section II. Repair parts for repairable special tools are also listed in the section.

b. Section III Special Tools List. A list of special tools, special TMDE, and other special support equipment authorized by this RPSTL (as indicated by Basis of Issue (BOI) information in DESCRIPTION AND USABLE ON CODE (UOC) column) for the performance of maintenance.

C-3. EXPLANATION OF COLUMNS . (Sections II and III).

a. FIG NO Column. Indicates the figure number that illustrates the item listed.

b. ITEM NO Column. Indicates the number used to identify items called out in the illustration.

b. SMR CODE Column. The Source, Maintenance, and Recoverability (SMR) code is a 5-position code containing supply/requisitioning information, maintenance category authorization criteria, and disposition instructions, as shown in the following breakout:

Source Code	Maintenance Code	Recoverability Code
XX	XX	X
1st two positions	3rd position	4th position
How you get an item.	Who can install replace or use the item.	Who can do complete repair on the item.
		5th position
		Who determines disposition action on an unserviceable item.

*Complete Repair: Maintenance capacity, capability, and authority to perform all corrective maintenance tasks of the "repair" function in a use/user environment in order to restore serviceability to a failed item (1) Source Code. The source code tells you how to get an item needed for maintenance, repair, or overhaul of an end item/equipment. Explanations of source codes follow:

Code	Explanation
PA	Stocked items; use the applicable NSN to request/requisition items with these source codes. They are authorized to the category indicated by the code entered in the third position of the SMR code.
PB	
PC**	
PD	
PE	
PF**	NOTE: Items coded PC are subject to deterioration.
KD	Items with these codes are not to be requested/requisitioned individually. They are part of a kit which is authorized to the maintenance category indicated in the 3rd position of the SMR code. The complete kit must be requisitioned and applied.
KF	
KB	
MO-(Made at org/ AVUM Level)	Items with these codes are not to be requested/requisitioned individually. They must be made from bulk material that is identified by the part number in the DESCRIPTION AND USABLE ON CODE (UOC) column and listed in the Bulk Material group of the repair parts list in this RPSTL. If the item is authorized to you by the 3rd position code of the SMR code, but the source code indicates it is made at a higher level, order the item from the higher level of maintenance.
MF-(Made at DS/ AVIM Level)	
MH-(Made at GS Level)	
ML-(Made at Spe- cialized Repair Act. (SRA))	
MD-(Made at Depot)	
AO-(Assembled by org/AVUM Level)	Items with these codes are not to be requested/requisitioned individually. The parts that make up the assembled item must be requisitioned or fabricated and assembled at the level of maintenance indicated by the source code. If the third position code of the SMR code authorizes you to replace the item, but the source code indicates the item is assembled at a higher level, order the item from the higher level of maintenance.
AF-(Assembled by DS/AVIM Level)	
AH-(Assembled by GS Category)	
AL-(Assembled by SRA)	
AD-(Assembled by Depot)	
XA	Do not requisition an 'XA' - coded item. Order its next higher assembly. (Also, refer to the NOTE below.)
XB	If an 'XB' item is not available from salvage, order it using the CAGEC and part number given.
XC	Installation drawing, diagram, instruction sheet, field service drawing, that is identified by manufacturer's part number.
XD	Item is not stocked. Order an 'XD' - coded item through normal supply channels using the CAGEC and part number given, if no NSN is available.

NOTE

Cannibalization or controlled exchange, when authorized, may be used as a source of supply for items with the above source codes, except for those source coded "XA" or those aircraft support items restricted by requirements of AR 700-42.

(2) *Maintenance Code.* Maintenance codes tell you the level(s) of maintenance authorized to use and repair support items. The maintenance codes are entered in the third and fourth positions of the SMR Code as follows:

(a) The maintenance code entered in the third position tells you the lowest maintenance level authorized to remove, replace, and use the support item. The maintenance code entered in the third position will indicate authorization to one of the following levels of maintenance.

Code	Application/Explanation
C	Crew or operator maintenance done within organizational or aviation unit maintenance.
O	Organizational or aviation unit category can remove, replace, and use the item.
F	Direct support or aviation intermediate level can remove, replace, and use the item.
H	General support level can remove, replace, and use the item.
L	Specialized repair activity can remove, replace, and use the item.
D	Depot level can remove, replace, and use the item.

(b) The maintenance code entered in the fourth position tells whether or not the item is to be repaired and identifies the lowest maintenance level with the capability to do complete repair (i.e., perform all authorized repair functions.) (NOTE: Some limited repair may be done on the item at a lower level of maintenance, if authorized by the Maintenance Allocation Chart (MAC) and SMR codes.) This position will contain one of the following maintenance codes.

Code	Application/Explanation
O	Organizational or aviation unit is the lowest level that can do complete repair of the item.
F	Direct support or aviation intermediate is the lowest level that can do complete repair of the item.
H	General support is the lowest level that can do complete repair of the item.
L	Specialized repair activity (designate the specialized repair activity) is the lowest level that can do complete repair of the item.
D	Depot is the lowest level that can do complete repair of the item.
Z	Nonrepairable. No repair is authorized.
B	No repair is authorized. (No parts or special tools are authorized for the maintenance of a "B" coded item.) However, the item may be reconditioned by adjusting, lubricating, etc., at the user level.

C-3. EXPLANATION OF COLUMNS. (Sections II and III). (CONT)

(3) *Recoverability Code.* Recoverability codes are assigned to items to indicate the disposition action on unserviceable items. The recoverability code is entered in the fifth position of the SMR Code as follows:

Code	Application/Explanation
Z	Nonrepairable item. When unserviceable, condemn and dispose of the item at the level of maintenance shown in 3rd position of SMR Code.
O	Repairable item. When uneconomically repairable, condemn and dispose of the item at organizational or aviation unit level.
F	Repairable item. When uneconomically repairable, condemn and dispose of the item at the direct support or aviation intermediate level.
H	Repairable item. When uneconomically repairable, condemn and dispose of the item at the general support level.
D	Repairable item. When beyond lower level repair capability, return to depot. Condemnation and disposal of item not authorized below depot level.
L	Repairable item. Condemnation and disposal not authorized below Specialized Repair Activity (SRA).
A	Item requires special handling or condemnation procedures because of specific reasons (e.g., precious metal content, high dollar value, critical material, or hazardous material). Refer to appropriate manuals/ directives for specific instructions.

d. NSN Column. This column lists the national stock number (NSN) for the item.

e. DESCRIPTION Column. This column describes the item including the manufacturer's part number or military standard and the Contractor And Government Entity Code (CAGEC).

f. UNIT OF ISSUE Column. This column lists the two-letter military code for the unit by which the item is issued from stock.

Section II. REPAIR PARTS LIST

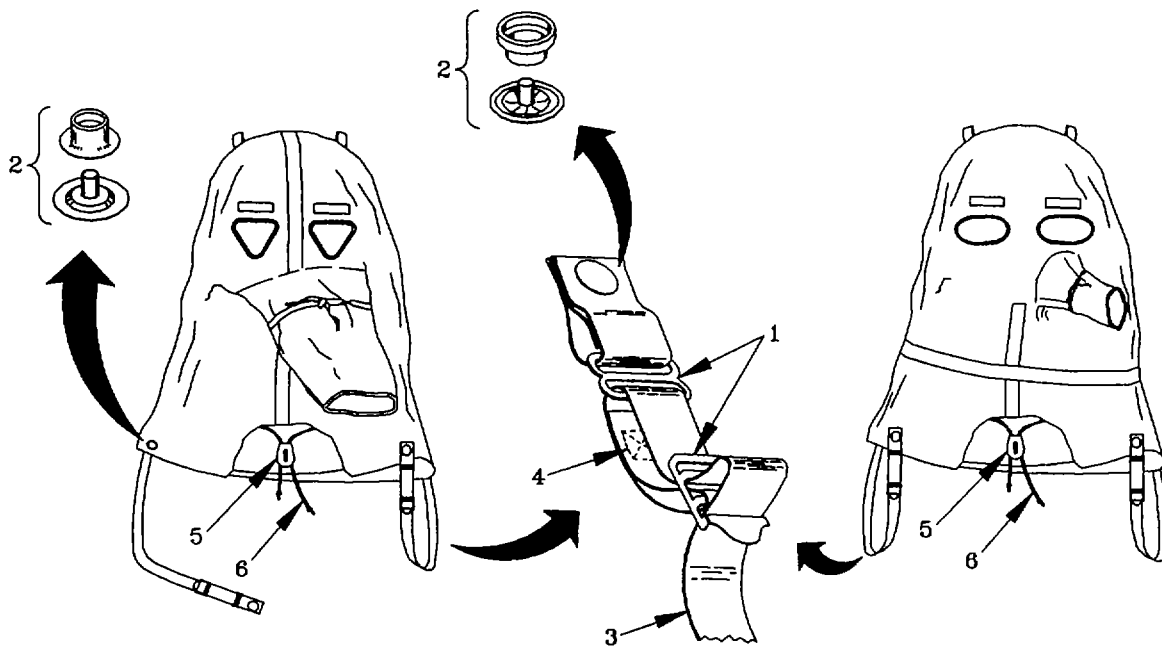


Figure C-1. M3 TAP/M40 Special Purpose TAP Hoods

FIG NO.	ITEM NO.	SMR CODE	NSN	DESCRIPTION	UNIT OF ISSUE
C-1	1	PAFZZ		M3 TAP/M40 TAP SPECIAL PURPOSE HOOD MATERIALS Buckle, Tongueless, One-bar, 5/8 in, Mil-B-643, Type I, Style 2, Class 1, Const B OR Buckle, Tongueless, Lip- Type, Two-bar, 5/8 in, Mil-B-543, Type U, Style 3, Class 1	EA
C-1	2	PAFZZ		Snap Fastener, Mil-F-10884, Style 2A, Finish 2	EA
C-1	3	XBFZZ		Cloth, Butyl Coated Nylon Mil-C-12189	YD
C-1	4	PAFZZ	8310-00-988-1298	Thread, Polyester, V-T-285, Type I, Class 1, Sub-class A, (70/3-ply), OD S-1, Size E	SL
C-1	5	PAFZZ		Cord Lock, Double cord 1-1/4 x 3/4 in. P/N: CORD-LOC194 (02768)	EA
C-1	6	PAFZZ	831-01-066-5850	Braid, Textile, Cotton OD-7, 188 in. Mil-B-371, Type HII, Class 4	YD
C-1	7	PAFZZ		Braid, Textile, Flat OD-7, .344 in. Mil-B-371, Type VII	YD

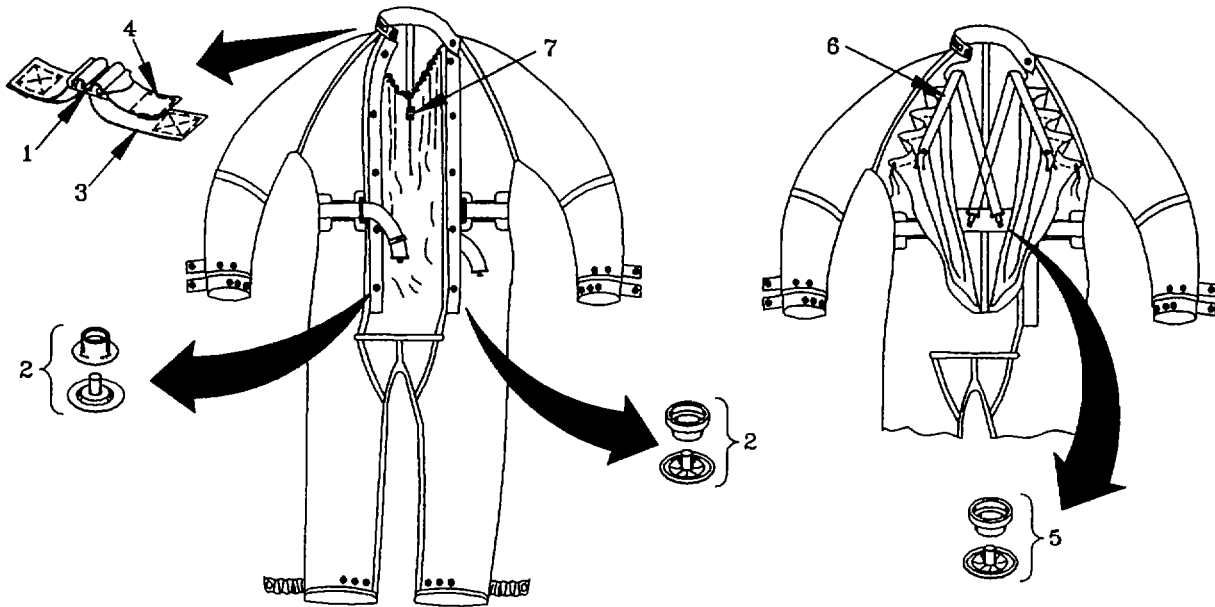


Figure C-2 M2 TAP Coverall

FIG NO.	ITEM NO.	SMR CODE	NSN	DESCRIPTION	UNIT OF ISSUE
C-2	1	PAFZZ		M3 TAP COVERALL MATERIALS Buckle, Mil-B-543, Type II, Style 4, Class 1, Construction B, Size 3/4 in	EA
C-2	2	PAFZZ	5325-00-292-5343	Snap Fastener, Mil-F-10884, Style 2, Finish 2	EA
C-2	3	MFFZZ	8305-00-260-1748	Webbing, MII-W-530, Type IIA, Class 4, 3/4 in. wide per MIL-C-2181, OD-7	RO
C-2	4	PAFZZ	8310-00-988-1298	Thread, Polyester, V-T-285, Type I, Class 1, Subclass A, OD S-1, Size E (70/3 ply)	TU
C-2	5	PAFZZ		Snap Fastener, MIL-F-10884, Style 2A, Finish 2	EA
C-2	6	PAFZZ	8440-01-287-0588 8440-00-221-0852	Suspenders, Mil-S-6790, Type I, OD-7, 1 5 in Wide X 34 in. Long or 1.5 in. Wide X 38 75 in Long	EA
C-2	7	PAFZZ		Cord Lock, 1-1/4 x 3/4 in., P/N 164, (02768)	EA

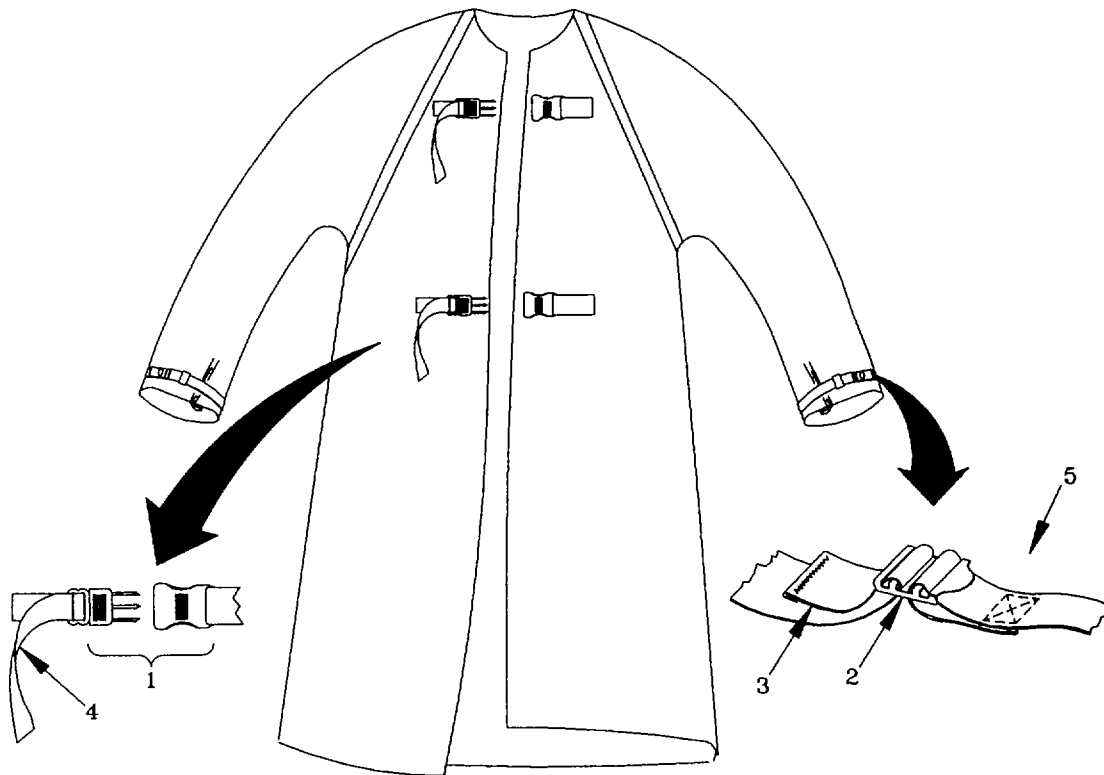


Figure C-3. M2 TAP Apron

FIG NO.	ITEM NO.	SMR CODE	NSN	DESCRIPTION	UNIT OF ISSUE
C-3	1	PAFZZ	8465-01-286-5352	Fastener, Quick Release Strap, 6-1047, CAGEC 81337	EA
C-3	2	PAFZZ		Buckle, Mil-B-543, Type II, Style 4, Class 3, Construction B, Size 5/8 m	EA
C-3	3	MFZZ		Webbing, Mil-W-530, Type IIA, Class 7, 6/8 m wide, OD-7	RO
C-3	4	MFFZZ		Webbing, Mil-W-630, CAGEC Type IMA, Class 7, 1 in wide, OD-7	RO
C-3	5	PAFZZ	8310-00-988-1298	Thread, Polyester, V-T-285, Type I, Class 1, Sub-class A, OD S-1, Size E, (70/3 ply)	TU

Section III. SPECIAL TOOLS LIST

not applicable

APPENDIX D

COMPONENTS OF END ITEM (COEI) AND BASIC ISSUE ITEMS (BII) LISTS

Section I. INTRODUCTION

D-1. SCOPE. This appendix lists components of the end item and basic issue items for the TAP Ensemble to help you inventory the items for safe and efficient operation of the equipment.

D-2. GENERAL. The Components of End Item (COEI) and Basic Issue Items (BII) Lists are divided into the following sections:

a. Section II, Components of End Item. This listing is for information purposes only, and is not authority to requisition replacements. These items are part of the TAP Ensemble. As part of the end item, these items must be with the end item whenever it is issued or transferred between property accounts. Items of COEI are removed and separately packaged for transportation or shipment only when necessary. Illustrations are furnished to help you find and identify the items.

b. Section III, Basic Issue Items. These essential items are required to place the TAP Ensemble in operation, operate it, and to do emergency repairs. Although shipped separately packaged, BII must be with the TAP Ensemble during operation and when it is transferred between property accounts. This list is your authority to request/requisition them for replacement based on authorization of the end item by the TOE/MTOE. Illustrations are furnished to help you find and identify the items.

D-3. EXPLANATION OF COLUMNS.

a. Column (1), Illus Number, gives you the number of the item illustrated.

b. Column (2), National Stock Number, identifies the stock number of the item to be used for requisitioning purposes.

c. Column (3), Description and Usable On Code, identifies the Federal item name (in all capital letters) followed by a minimum description when needed. The last line below the description is the Commercial and Government Entity Code (CAGEC) (in parentheses) and the part number.

If the item you need is not the same for different models of the equipment, a Usable On Code will appear on the right side of the description column on the same line as the part number. These codes are identified below:

CODE USED ON

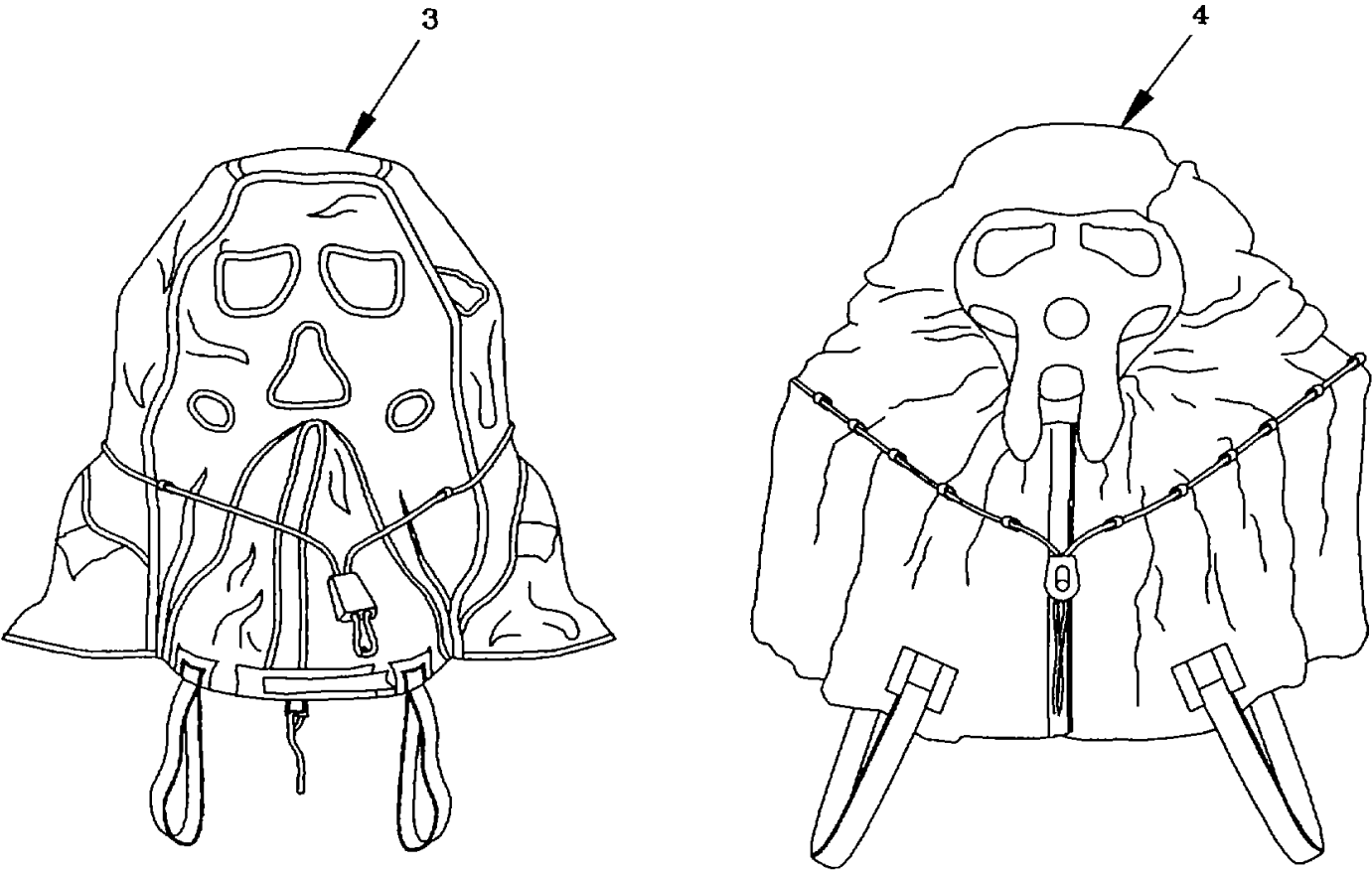
d. Column (4), U/I (unit of issue), indicates how the item is issued for the National Stock Number shown in column two.

e. Column (5), Qty Rqd, indicates the quantity required.

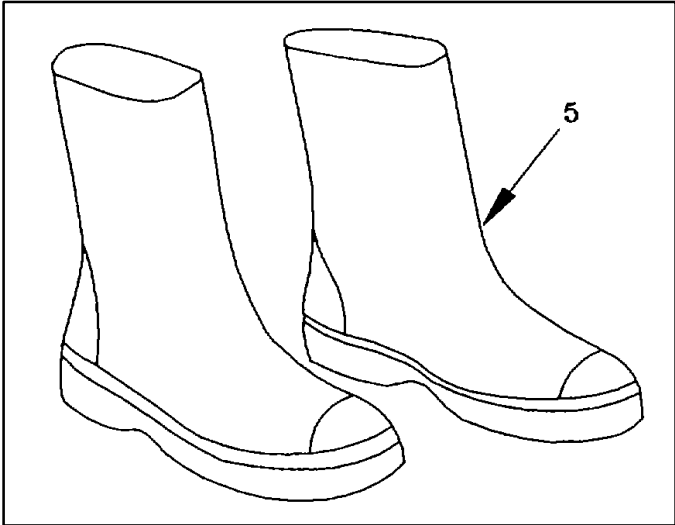
Section II. COMPONENTS OF END ITEM

(1) Illus Number	(2) National Stock Number	(3) Description CAGEC and Part Number	(4) Usable On Code U/M	(5) Qty Rqr
1	8415-00-261-6690	HOOD, GAS MASK TOXICOLOGICAL AGENTS PROTECTIVE, M3 (81349) MIL-H-12225	EA	1
2		HOOD, GAS MASK, SPECIAL PURPOSE, TOXICOLOGICAL AGENTS PROTECTIVE, M40 (81349) MIL-H44428	EA	1

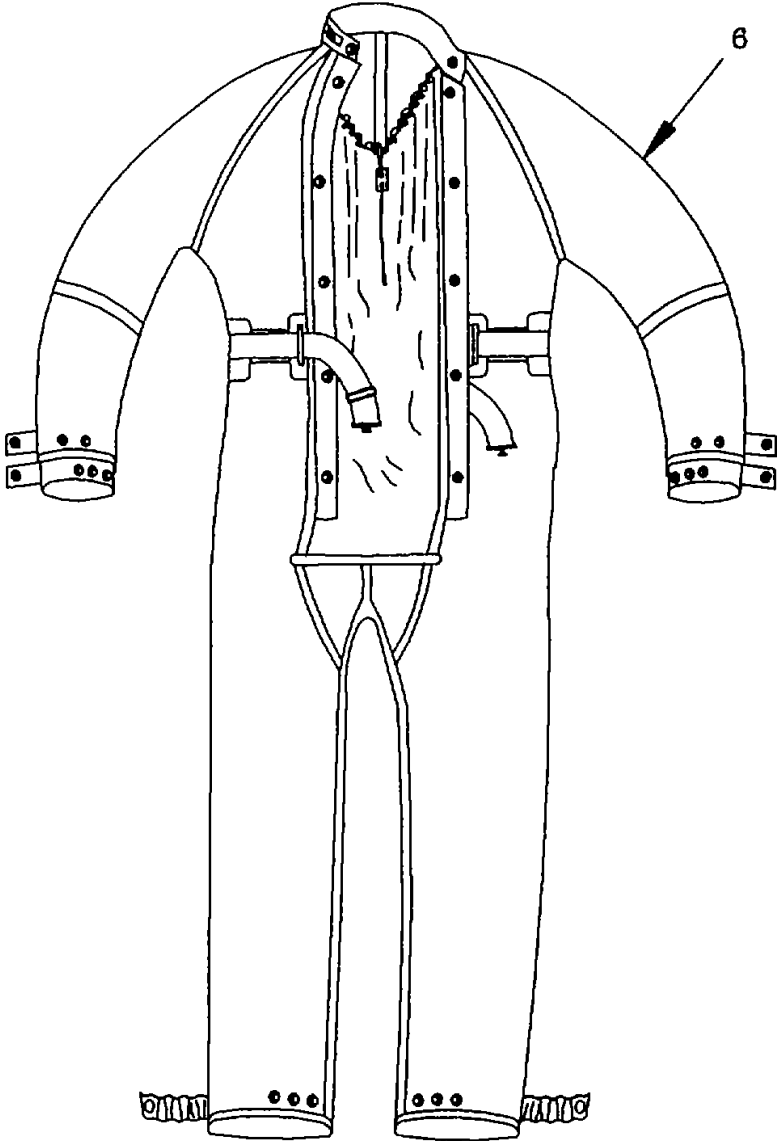
Section II. COMPONENTS OF END ITEM (CONT)

(1) Illus Number	(2) National Stock Number	(3) Description CAGEC and Part Number	(4) Usable On Code U/M	(5) Qty Rqr
				
3	4240-00-999-0420	HOOD, CHEMICAL-BIOLOGICAL, MASK FIELD, ABC-M6A2 (81349) MIL-H-51291	EA	1
4	4240-01-260-8723	HOOD, CHEMICAL-BIOLOGICAL, MASK (GENERAL PURPOSE), M40	EA	1

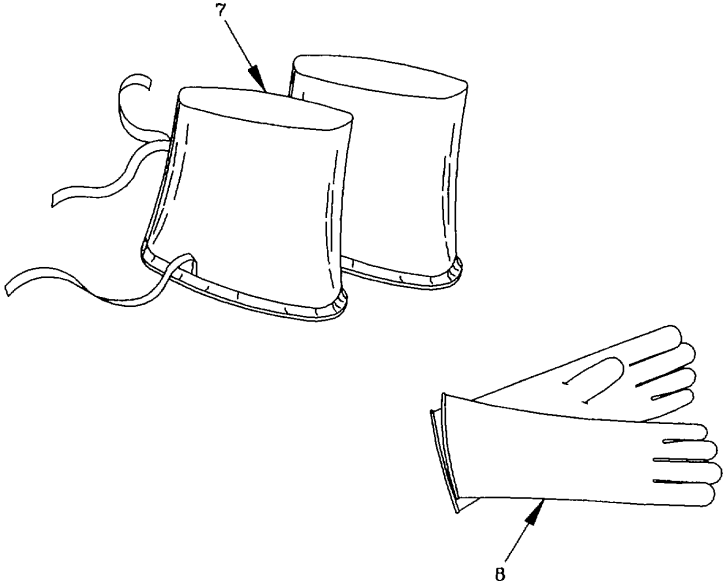
Section II. COMPONENTS OF END ITEM (CONT)

(1) Illus Number	(2) National Stock Number	(3) Description CAGEC and Part Number	(4) Usable On Code U/M	(5) Qty Rqr
5	8430-00-820-6304 8430-00-820-6303 8430-00-820-6306 8430-00-820-6302 8430-00-820-6301 8430-00-820-6300 8430-00-820-6299 8430-00-820-6298 8430-00-820-6297 8430-00-820-6296 8430-00-820-6295	 <p>BOOTS, TOXICOLOGICAL AGENTS PROTECTIVE, M2A1 (81349) MIL-B-51176 Size 5 Size 6 Size 7 Size 8 Size 9 Size 10 Size 11 Size 12 Size 13 Size 14 Size 15</p>	PR	AR

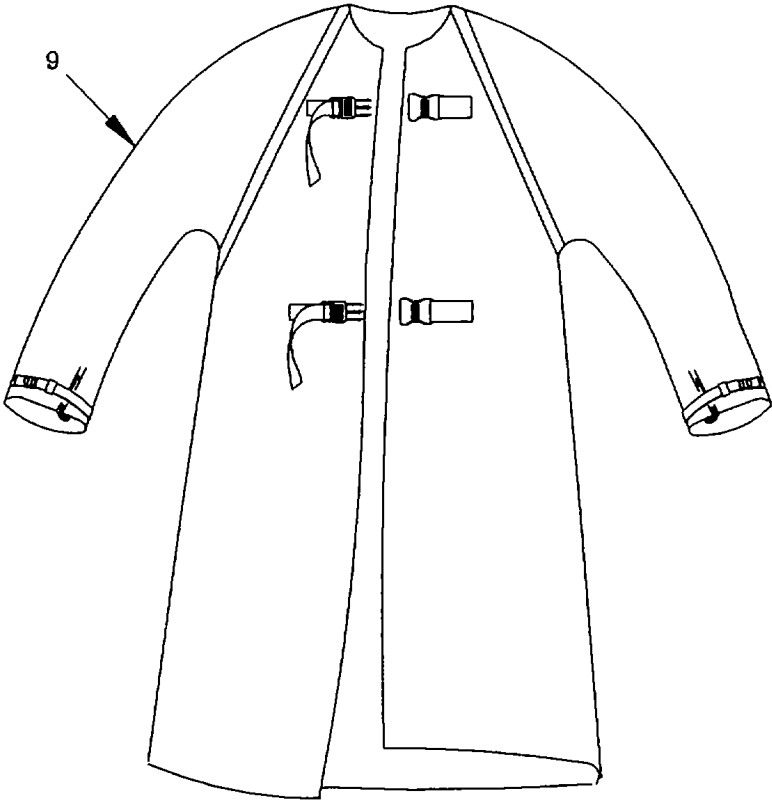
Section II. COMPONENTS OF END ITEM (CONT)

(1) Item Number	(2) National Stock Number	(3) Description CAGEC and Part No	(4) Usable On Code	(5) Qty Req
				
6	8415-00-099-6962 8415-00-099-6968 8415-00-099-6970 8415-01-105-2535	COVERALLS, TOXICOLOGICAL AGENTS PROTECTIVE, M3 (81349) MIL-C-2181 Size: Small Size: Medium Size: Large Size: X-Large	EA	AR

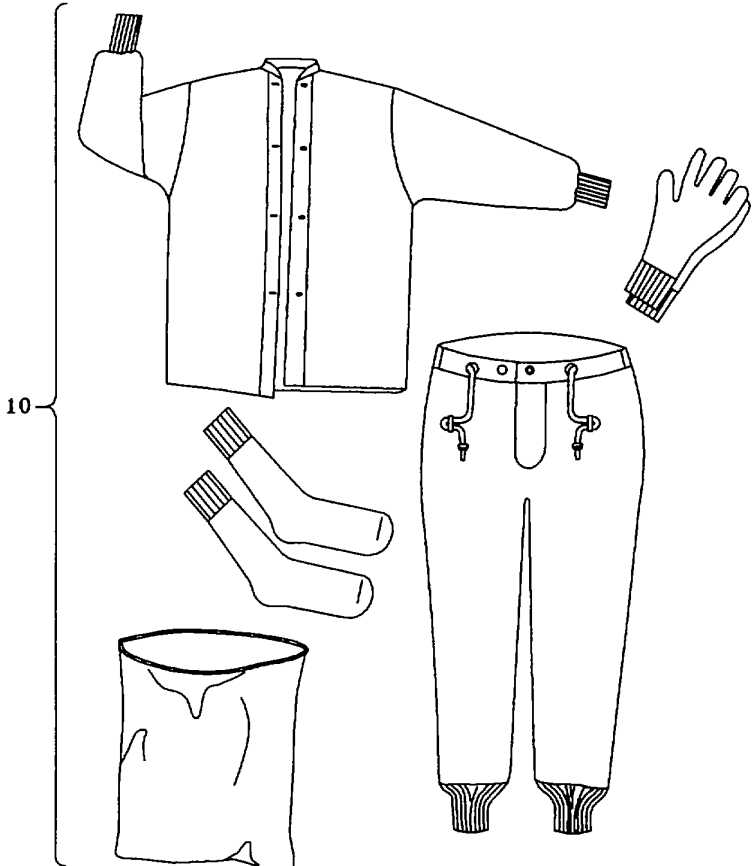
Section II. COMPONENTS OF END ITEM (CONT)

(1) Item Number	(2) National Stock Number	(3) Description CAGEC and Part No	(4) Usable On Code	(5) Qty Req
				
7	8430-00-262-5295 8430-00-262-5297 8430-00-262-5296	FOOTWEAR COVER, TOXICOLOGICAL AGENTS PROTECTIVE, M1 (81349) MIL-F-12224 Size: Small Size: Medium Size: Large	EA	AR
8	8416-00-753-6550 8415-00-753-6551 8415-00-753-6552 8415-00-753-6553 8415-00-753-6554	GLOVES, TOXICOLOGICAL AGENTS PROTECTIVE, M3 (81337) MIL-G-12223, TYPE II Size: X-Small Size: Small Size: Medium Size: Large Size: X-Large	PR	AR
8	8415-00-820-6294 8415-00-820-6305 8415-00-820-6293	GLOVES, TOXICOLOGICAL AGENTS PROTECTIVE, M4 (81337) MIL-G-12223, TYPE IIA Size: Small Size: Medium Size: Large	PR	AR

Section II. COMPONENTS OF END ITEM (CONT)

(1) Item Number	(2) National Stock Number	(3) Description CAGEC and Part No	(4) Usable On Code	(5) Qty Req
				
9	8415-00-281-7812 8415-00-281-7818 8415-00-281-7814 8415-00-281-7815 8415-00-281-7816	APRON, TOXICOLOGICAL AGENTS PROTECTIVE, M2 (81349) MIL-A-2334 Size. X-Small Size Small Size Medium Size Large Size X-Large	EA	AR

Section II. COMPONENTS OF END ITEM (CONT)

(1) Item Number	(2) National Stock Number	(3) Description CAGEC and Part No	(4) Usable On Code	(5) Qty Req
				
10	8415-00-782-3240	CLOTHING OUTFIT, CHEMICAL PROTECTIVE (IMPREGNATED SET)	EA	AR
	8415-00-782-3221	Socks, Chemical Protective Size: XSmall	PR	8
	8415-00-782-8239	Gloves, Chemical Protective Size: Small, (81849) MIS-48	PR	1
	8415-00-900-8241	Liner, Shirt Chemical Protective, Size: XSmall (81549) MIL48582	EA	1
	8415-00-900-8283	Liner, Trousers Chemical Protective, Size: XSmall (81849) MIIL-48579	EA	1
	8415-00-141-0832	Bag, Chemical Protective Clothing Outfit (81849) M,-B48587 Basic	EA	1

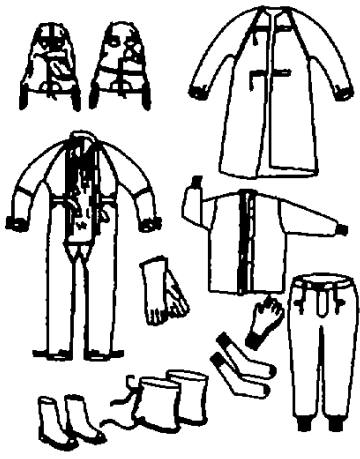
Section II. COMPONENTS OF END ITEM (CONT)

(1) Item Number	(2) National Stock Number	(3) Description CAGEC and Part No	(4) Usable On Code U/I	(5) Qty Req
10	8415-00-782-3241	CLOTHING OUTFIT, CHEMICAL PROTECTIVE (IMPREGNATED SET) Size: Small	EA	AR
	8415-00-782-3222	Socks, Chemical Protective Size: Medium, (81349) MIL-S48	PR	3
	8415-00-782-3245	Gloves, Chemical Protective Size: Medium, (81349) ML-G-1057	PR	1
	8415-00-900-8242	Liner, Shirt Chemical Protective, Size: Small (81349) MIL-L-43582	EA	1
	8415-00-900-8284	Liner, Trousers Chemical Protective, Size: Small (81849) MILL-43579	EA	1
	8415-00-141-0832	Bag, Chemical Protective Clothing Outfit (81349) MIB-43587 Basic	EA	1
10	8415-00-782-3242	CLOTHING OUTFIT, CHEMICAL PROTECTIVE (IMPREGNATED SET) Size: Medium	EA	AR
	8415-00-782-3222	Socks, Chemical Protective Size: Medium, (81349) MIL-S-48	PR	3
	8415-00-782-3246	Gloves, Chemical Protective Size: Large, (81349) MIG-1057	PR	1
	8415-00-900-8243	Liner, Shirt Chemical Protective, Size: Medium (81349) MIL-L43582	EA	1
	8415-00-900-8285	Liner, Trousers Chemical Protective, Size: Medium (81349) MIL-L43579	EA	1
	8415-00-141-0832	Bag, Chemical Protective Clothing Outfit (81349) MIL-B-43587 Basic	EA	1
10	8415-00-782-3243	CLOTHING OUTFIT, CHEMICAL PROTECTIVE (IMPREGNATED SET) Size: Large	EA	AR
	8415-00-782-3223	Socks, Chemical Protective Size: Large, (81349) MIL-S-48	PR	3
	8415-00-782-3246	Gloves, Chemical Protective Size: Large, (81349) MIL-G-1057	PR	1
	8415-00-900-8244	Liner, Shirt Chemical Protective, Size: Large (81349) MIL-L43582	EA	1
	8415-00-900-8286	Liner, Trousers Chemical Protective, Size: Large (81349) MIL-L-43579	EA	1
	8415-00-141-0832	Bag, Chemical Protective Clothing Outfit (81349) MIL-B-43587	EA	1

Section II. COMPONENTS OF END ITEM (CONT)

(1) Item Number	(2) National Stock Number	(3) Description CAGEC and Part No	(4) Usable On Code U/I	(5) Qty Req
10	8415-00-782-3244	CLOTHING OUTFIT, CHEMICAL PROTECTVE (IMPREGNATED SET) Size: X-Large	EA	AR
	8415-00-782-3223	Socks, Chemical Protective Size: Large, (81349) MIL-S48	PR	9
	8415-00-782-3246	Gloves, Chemical Protective Size: Large, (81349) MIL-G-1067	PR	1
	8415-00-900-8245	Liner, Shirt Chemical Protective, Size: X-Large (81349) MIL-L-43582	EA	1
	8415-00-900-8287	Liner, Trousers Chemical Protective, Size: X-Large (81349) MIL-L-43579	EA	1
	8415-00-141-0832	Bag, Chemical Protective Clothing Outfit (81349) MIL-B43587 Basic	EA	1

Section III. BASIC ISSUE ITEMS

(1) Item Number	(2) National Stock Number	(3) Description CAGEC and Part No	(4) Usable On Code	(5) Qty Req																																							
		<div style="border: 1px solid black; padding: 10px; text-align: center;"> <p>TM 10-8415-210-13&P</p> <hr/> <p>TECHNICAL MANUAL</p> <p>OPERATOR'S, UNIT AND DIRECT SUPPORT MAINTENANCE MANUAL INCLUDING REPAIR PARTS AND SPECIAL TOOLS LIST FOR THE TOXICOLOGICAL AGENT PROTECTIVE (TAP) ENSEMBLE</p>  <table border="1" data-bbox="950 793 1307 1218"> <tr><td>CHAPTER 1</td><td>INTRODUCTION</td><td>A-1</td></tr> <tr><td>CHAPTER 2</td><td>OPERATIONAL INSTRUCTIONS</td><td>A-1</td></tr> <tr><td>CHAPTER 3</td><td>OPERATIONAL PERFORMANCE</td><td>A-1</td></tr> <tr><td>CHAPTER 4</td><td>MAINTENANCE</td><td>A-1</td></tr> <tr><td>APPENDIX A</td><td>REFERENCES</td><td>A-1</td></tr> <tr><td>APPENDIX B</td><td>MAINTENANCE AND REPAIR CHECK LIST</td><td>B-1</td></tr> <tr><td>APPENDIX C</td><td>REPAIR PARTS AND SPECIAL TOOLS LIST</td><td>C-1</td></tr> <tr><td>APPENDIX D</td><td>CONTENTS OF BROWN LIST</td><td>B-1</td></tr> <tr><td>APPENDIX E</td><td>ACCIDENTAL RELEASES</td><td>B-1</td></tr> <tr><td>APPENDIX F</td><td>REPAIR PARTS AND SPECIAL TOOLS LIST</td><td>A-1</td></tr> <tr><td>APPENDIX G</td><td>ABBREVIATIONS AND SYMBOLS</td><td>A-1</td></tr> <tr><td>GLOSSARY</td><td></td><td>GLOSSARY 1</td></tr> <tr><td>ALPHABETICAL INDEX</td><td></td><td>INDEX 1</td></tr> </table> <hr/> <p>HEADQUARTERS, DEPARTMENT OF THE ARMY 11 JANUARY 1984</p> </div>	CHAPTER 1	INTRODUCTION	A-1	CHAPTER 2	OPERATIONAL INSTRUCTIONS	A-1	CHAPTER 3	OPERATIONAL PERFORMANCE	A-1	CHAPTER 4	MAINTENANCE	A-1	APPENDIX A	REFERENCES	A-1	APPENDIX B	MAINTENANCE AND REPAIR CHECK LIST	B-1	APPENDIX C	REPAIR PARTS AND SPECIAL TOOLS LIST	C-1	APPENDIX D	CONTENTS OF BROWN LIST	B-1	APPENDIX E	ACCIDENTAL RELEASES	B-1	APPENDIX F	REPAIR PARTS AND SPECIAL TOOLS LIST	A-1	APPENDIX G	ABBREVIATIONS AND SYMBOLS	A-1	GLOSSARY		GLOSSARY 1	ALPHABETICAL INDEX		INDEX 1		
CHAPTER 1	INTRODUCTION	A-1																																									
CHAPTER 2	OPERATIONAL INSTRUCTIONS	A-1																																									
CHAPTER 3	OPERATIONAL PERFORMANCE	A-1																																									
CHAPTER 4	MAINTENANCE	A-1																																									
APPENDIX A	REFERENCES	A-1																																									
APPENDIX B	MAINTENANCE AND REPAIR CHECK LIST	B-1																																									
APPENDIX C	REPAIR PARTS AND SPECIAL TOOLS LIST	C-1																																									
APPENDIX D	CONTENTS OF BROWN LIST	B-1																																									
APPENDIX E	ACCIDENTAL RELEASES	B-1																																									
APPENDIX F	REPAIR PARTS AND SPECIAL TOOLS LIST	A-1																																									
APPENDIX G	ABBREVIATIONS AND SYMBOLS	A-1																																									
GLOSSARY		GLOSSARY 1																																									
ALPHABETICAL INDEX		INDEX 1																																									
1		OPERATOR'S, UNIT, AND DRECT SUPPORT MAINTENANCE MANUAL INCLUDING REPAIR PARTS AND SPECIAL TOOLS LIST (RPSTL), TM 10-8415-210-13&P	EA	1																																							

APPENDIX E

ADDITIONAL AUTHORIZATION LIST

Section I. INTRODUCTION

E-1. SCOPE. This appendix lists additional items that you are authorized for the support of the TAP Ensemble.

E-2. GENERAL. This list identifies items that do not have to accompany the TAP Ensemble and that do not have to be turned in with it. These items are authorized to you by CTA, MTOE, TDA, or JTA.

E-3. EXPLANATION OF LISTING. National Stock Numbers, description, and quantities are provided to help you identify and request the additional items you require to support this equipment. If the item required differs for different models of this equipment, see the "Used On Code" column for the applicable model or models.

Section II. ADDITIONAL AUTHORIZATION LIST

(1) National Stock Number	(2) Description CAGEC & Part Number Usable on Code	(4) U/M	(5) Qty Auth
8416-00-280-2455 8415-00-279-8719 8415-00-279-8720 8415-00-279-8721 8415-00-279-8722	COVERALLS, EXPLOSIVE HANDLERS, COTTON SATEEN, FIRE RESISTANT, (81349) MIL-C-14610 Size XSmall Size Small Size Medium Size Large Size X-Large	EA	AR

E-1/(E-2 blank)

APPENDIX F

EXPENDABLE AND DURABLE ITEMS LIST

Section I. INTRODUCTION

F-1. SCOPE. This appendix lists expendable and durable items that you will need to operate and maintain the TAP Ensemble. This listing is for information only and is not authority to requisition the listed items. These items are authorized to you by CTA 50-790, Expendable/Durable Items (except medical, class V repair parts, and heraldic items), or CTA 8-100, Army Medical Department Expendable/Durable Items.

F-2. EXPLANATION OF COLUMNS.

- a. Column 1. Item number. This number is assigned to the entry in the listing and is referenced in the narrative instructions to identify the item (e.g. "Use cleaning compound, item 5, Appendix F".)
- b. Column 2. Level. This column identifies the lowest level of maintenance that requires the item.
- c. Column 3. National Stock Number. This is the national stock number assigned to the item which you can use to requisition it.
- d. Column 4. Item Name, Description, Commercial and Government Entity Code (CAGEC), and Part Number. This provides the other information you need to identify the item.
- e. Column 5. Unit of Measure. This code shows the physical measurement or count of an item, such as gallon, dozen, gross, etc.

Section II. EXPENDABLE/DURABLE SUPPLIES AND REQUIREMENTS LIST

(1) Item Number	(2) Level	(3) National Stock Number	(4) Item Name, Description CAGEC, Part Number	(5) U/M
1	0	7510-00-164-8893	CHALK, WHITE, GRADE B	GR
2	0	7510-00-074-4955	TAPE, PRESSURE SENSITIVE	RL
3	F	8040-00-74-2685	ADHESIVE, CARBOLENE NEOPRENE F-1	GL
4	F	60S4-00-205-613	ALCOHOL, ISOPROPYL, USP	BT
5	F	7920-00-514-2417	BRUSH, ACID SWABBING	GR
6	F	8020-00-685-5394	BRUSH, PAINT, 3.5 INCH	EA
7	F	7240-00-138-7983	CUP, MEASURING	EA
8	F	5110-00-203-46652	FILE, HAND	EA
9	F		GERAPON, T77	GL
10	F		GLOVES, SURGICAL	PR
11	F	510-00-2316531	INK PAD, RUBBER STAMP	EA
12	F		INK, STENCIL, BLACK	GL
		7510-00-161-0811	WHITE	
		7510-00-161-0815	YELLOW	
		7510-00-161-0816		
13	F	7510-00-230-2734	MARKER, FELT TIP, BLACK	EA
14	F	6515-00-754-2834	NEEDLE, 18 GAUGE	EA
15	F		pH PAPER	SH
16	F	5120-00-243-9401	ROLLER, HAND, 2 INCH	
17	F	7930-00-224-7901	SOAP, LAUNDRY, POWDER	LB
	F	7930-01-082-0584	SOAP, LAUNDRY, POWDER	LB
	F	7930-00-634-3935	SOAP, LAUNDRY, FLAKED	LB
	F	8520-00-228-0598	SOAP, LIQUID, TYPE I, TOILET	GL
18	F		STENCIL ROLLER, W/HANDLE	EA
19	F	6515-00-09-1875	SYRINGE, GLASS, 10ml	EA
20	F	8135-00-178-9191	TAG, SHIPPING	MX
21	F	6810-00-142-9849	TALC, TECH, T-3	LB
22	F		THERMOMETER, TEL TRU NO 1D606 C, RANGE 60 -500 F	EA
23	F	6810-01-100-4176	TOLUENE, REAGENT (87570) H602NT	GL

APPENDIX G

ILLUSTRATED LIST OF MANUFACTURED ITEMS

G-1. SCOPE. This appendix includes simplified line drawings for each item authorized to be manufactured/fabricated, modified or mounted by Direct Support Maintenance Personnel.

G-2. INTRODUCTION.

a. This appendix includes complete instructions for making items authorized to be manufactured or fabricated at Direct Support Maintenance.

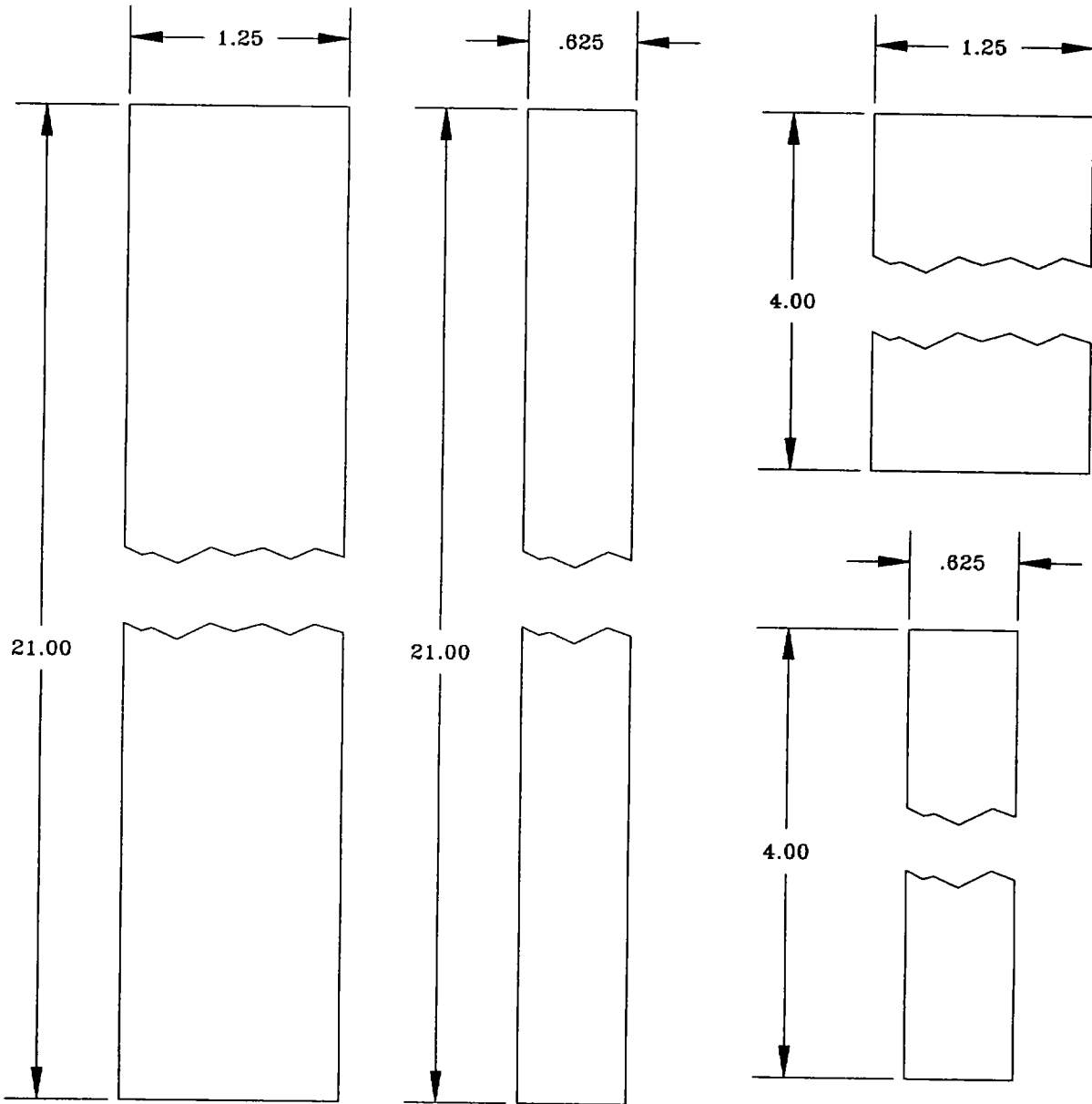
b. A part number in alphanumeric order is provided for cross-referencing the part number of the item to be manufactured to the figure which covers fabrication criteria.

c. All bulk materials needed for manufacture of an item are listed by part number or specification number in a tabular list on the illustration.

d. All dimensions are given in U.S. Standard measures.

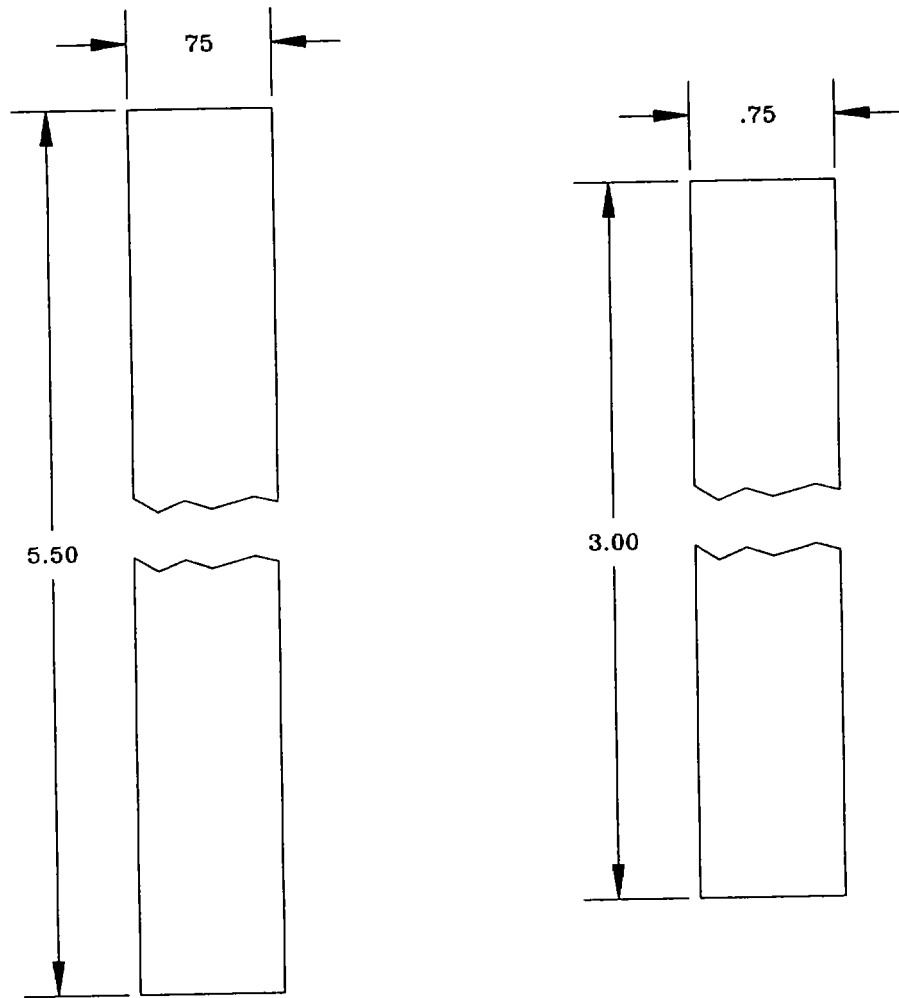
G-3. MANUFACTURED ITEMS PART NUMBER INDEX.

PART NUMBER	NOMENCLATURE	FIG NO
	Strap	1
	Strap	2
	Strap	3
	Strap	4



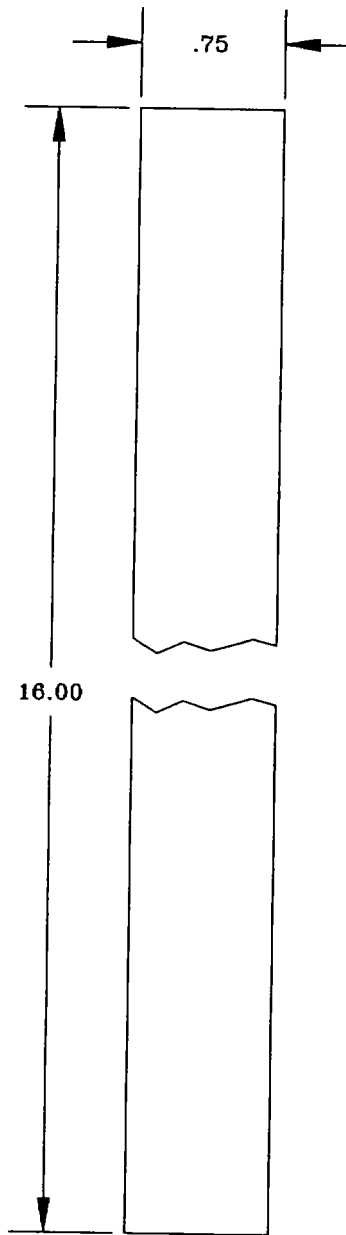
1. MAKE FROM ,IL-C-12189, CLOTH, BUTYL COATED NYLON.
2. GLUE WTIH ADHESIVE CARBOLINE.

Figure G-1. STRAP



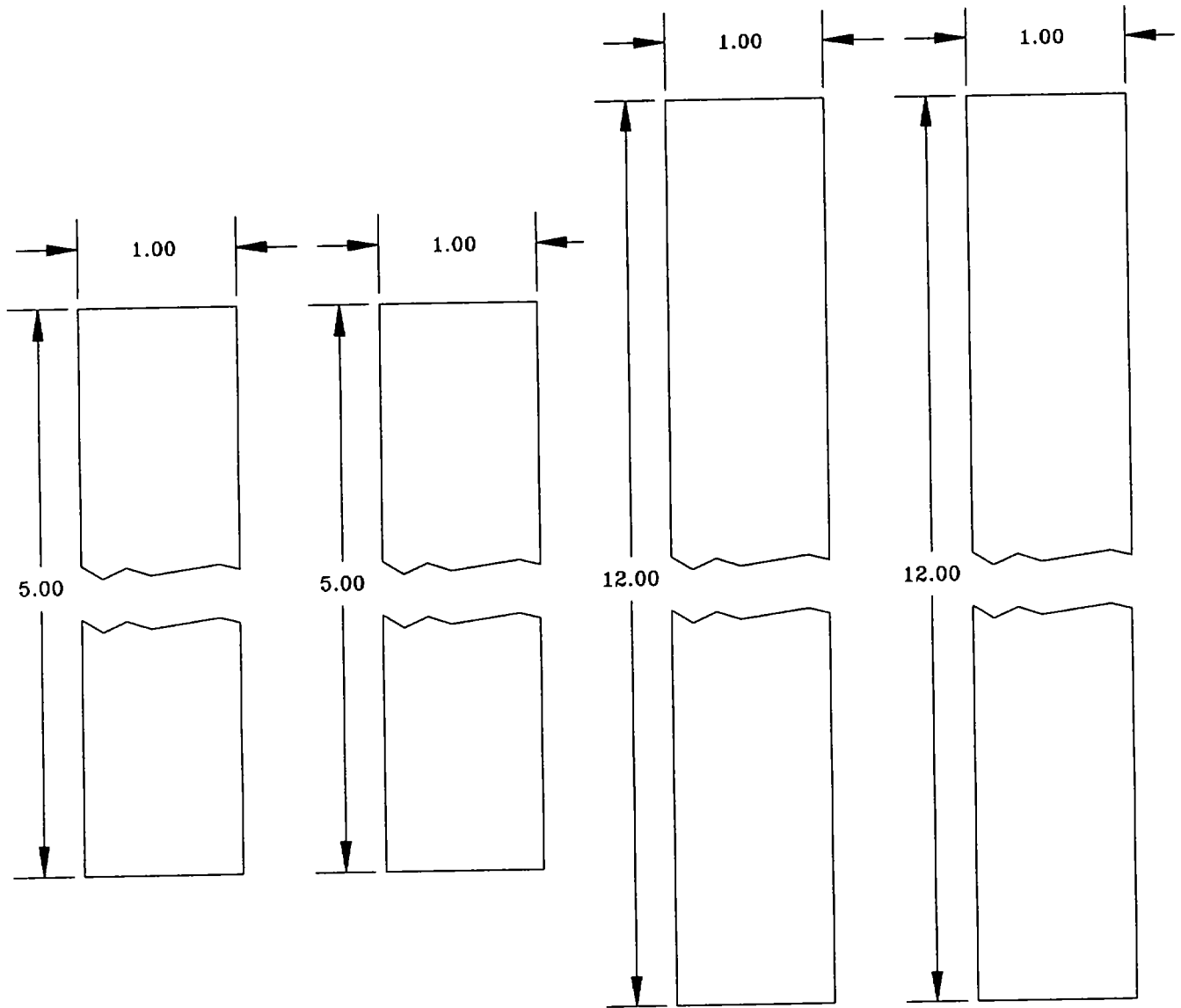
1. MAKE FROM MIL-W-530, WEBBING, TYPE IIA, CLASS 4, 3/4 IN. WIDE, OD-7.

Figure G-2. STRAP



1. MAKE FROM MIL-W-530, WEBBING, TYPE IIA, CLASS 7, 5/8 IN. WIDE, OD-7.

Figure G-3. STRAP



1. MAKE FROM MIL-W-530, WEBBING, TYPE IIA, CLASS 7, 5/8 IN. WIDE, OD-7.

Figure G-4. STRAP

G-5/(G6 blank)

GLOSSARY

Blister agent	Normally a mustard agent dispensed in vapor or liquid form that can be persistent or nonpersistent.
Blister	A raised bubble or peak-out of surface coat; raised spot or void.
Crack	A Break in coating, usually resulting from a crease.
Crease	A fold or pleat; doubling of surface that do not adhere to one another and that cannot be corrected by manual pressure.
Cut	An opening made with a sharp edged object.
Delamination	Surface coat removed, scraped, peeled or otherwise taken away from the cloth; separation of coating from base cloth; separation of one cloth; separation of one cloth from another in a plied material.
Dry Rot	Fissured surface condition generally due to weathering, light, heat or repeated bending or stretching.
Embedded foreign matter	Inclusion; foreign matter that on removal leaves an uncoated, or poorly coated area or a hole.
GB	An anticholinesterase compound that effects the nervous system.
Hole	An opening of undetermined cause. An area not covered by base cloth and coating compound.
Lump	An agglomerate of coating compound. Undiluted coating stock Imbedded foreign material; surface protrusion usually of the base coating material as distinguished from embedded foreign material.
Pit	A spherical depression, usually of small circumference.
Pleat/Pleating	See Crease.
Pucker	Indentation resulting from shrinkage of cloth. May also be caused by improper tension of knife dragging during coating.
Raw Edge	See Rip.
Rip	Cut or torn roughly.
Seam Air Void	See Blister
Slurry	A mixture of water and subtropical bleach for use in NBC decontamination procedures.

Tacky	Sticky.
Tear	Split, pulled-apart, see Rip.
Tunnel	An elongation area between coating, or between cloth and coating.
Uncoated Area	No visible coating applied.
VX	An anticholinesterase compound that effects the nervous system.
Wrinkle	See Crease.

Glossary-2

ALPHABETICAL INDEX

A

Abbreviations and Terms, List of, 1-9
 Additional Authorization List, Appendix E
 Applicability of, Levels of Protection and,
 TAP Ensemble Components, 2-3
 Assembly and Preparation for Use, 2-2

B

Basic Issue Items, Appendix D
 Biological, Chemical and, Protection, 1-14

C

Characteristics, Capabilities, and Features,
 Equipment, 1-10
 Checks and Services, Preventive
 Maintenance, Operators General, 2-1
 Chemical and Biological Protection, 1-14
 Cleaning, 3-2
 Common Tools and Equipment, 5-1
 Components of End Item and Basic Issue
 Items List, Appendix D
 Corrosion Prevention and Control (CPC), 1-8
 Cross-Reference, Nomenclature, 1-6

D

Decals and Instruction Plates, 2-10
 Decontaminate, 5-6
 Description of Major Components, Location
 and, 1-11
 Destruction of Material to Prevent Enemy
 Use, 1-3
 Differences Between Models, 1-12
 Doffing TAP Ensemble for Level A, 2-7
 Doffing TAP Ensemble for Level B, 2-8
 Doffing TAP Ensemble for Level C and D, 2-9
 Doffing TAP in Chemical Environment, 2-12
 Donning TAP Ensemble for Level A, 2-4
 Donning TAP Ensemble for Level B, 2-5
 Donning TAP Ensemble for Level C and D,
 2-6
 Durable Supplies and Materials List,
 Expendable/, Appendix F

E

Emergency Doffing of TAP, 2-13
 End Item, Components of, Appendix D
 Equipment Characteristics, Capabilities and
 Features, 1-10
 Equipment Improvement Recommendations
 (EIR), Reporting, 1-7
 Expendable/Durable Supplies and Materials
 List, Appendix F

F

Features, Equipment Characteristics,
 Capabilities and, 1-10
 Footwear Covers, Repair, 5-15
 Forms and Records, Maintenance, 1-2

G

Glossary, Glossary-i

I

Illustrated List of Manufactured Items,
 Appendix G
 Improvement Recommendations (EIR),
 Reporting Equipment, 1-7
 Inspection, 3-1
 Introduction to Operator PMCS, 2-1

L

Laundering Chemical Protective Clothing
 Outfit, 5-18
 Laundering TAP Components, 5-7
 Levels of Protection and Applicability of TAP
 Ensemble Components, 2-3
 List of Abbreviations and Terms, 1-9
 Location and Description of Major
 Components, 1-11

ALPHABETICAL INDEX (CONT)

M

M2 TAP Aprons, Repair, 5-17
 M2A1 TAP Boots, Inspect, Test, 5-13
 M3 TAP Coveralls, Inspect and Test, Repair,
 5-14
 M3/M4 TAP Gloves, Inspect, Test, 5-16
 M3 TAP Hood, Special Purpose Hood,
 Inspect, Repair, 5-13
 Maintenance Allocation Chart (MAC),
 Appendix B
 Maintenance Forms and Records, 1-2
 Maintenance, General, Direct Support, 5-5
 Major Components, Location and Description
 of, 1-11
 Materials List, Expendable/Durable Supplies
 and, Appendix F

N

Nomenclature Cross-Reference, 1-

O

Operation Under Unusual Conditions,
 General, Chap 2, Sec III
 Operation Under Usual Conditions, Chap 2,
 Sec II
 Operator PMCS, Introduction, 2-1

P

Parts, Repair, 5-3
 PMCS, Introduction to, 2-1
 Preparation for Storage or Shipment, 1-4, 4-5
 Preparation for Storage, 4-3
 Preservation, 4-4
 Prevent Enemy Use, Destruction of Material
 to, 1-3
 Protection, Levels of and Applicability of TAP
 Ensemble Components, 2-3

Q

Quality Assurance, 1-5

R

References, Appendix A
 Repairs of Butyl Material, Patch 5-9
 Repair M1 TAP Footwear Covers, 5-15
 Repair M2 TAP Apron, 5-17
 Repair M3 TAP Coveralls, 5-14
 Repair M3 TAP Hoods, 5-12
 Repair Parts, 5-3
 Repair Strapping and Tunnels, 5-10
 Reporting Equipment Improvement
 Recommendations (EIR), 1-7

S

Scope, 1-1
 Service Upon Receipt of Materials, 4-2
 Shipment, Preparation for, 4-5
 Snap fasteners, Replace, 5-11
 Special Tools, TMDE, and Support
 Equipment, 5-2
 Stitches, Seams and Stitching, 5-8
 Storage, Preparation for, 1-4, 4-3
 Strapping, and Tunnels, Repair, 5-10
 Supplies and Materials List,
 Expendable/Durable, Appendix F

T

Terms, List of Abbreviations and, 1-9
 Tool and Test Equipment List, Appendix B
 Tunnels, Strapping and, Repair, 5-10

U

Unit Maintenance Procedures, General, 4-7
 Unusual Conditions, Operation Under,
 General, Chap 2, Sec III

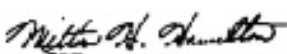
W

Wear Time Limitations, 2-11

By Order of the Secretary of the Army:

GORDON R. SULLIVAN
General, United States Army
Chief of Staff

Official:



MILTON H. HAMILTON
Administrative Assistant to the
Secretary of the Army
08137

DISTRIBUTION:

To be distributed in accordance with DA Form 12-36-E, block 9797 requirements for TM 11-6665-365-12&P.

* U.S. GOVERNMENT PRINTING OFFICE: 1995- 610-115/20108

RECOMMENDED CHANGES TO EQUIPMENT TECHNICAL PUBLICATIONS

 <p style="font-size: small; margin: 0;"><i>THEN...JOT DOWN THE DOPE ABOUT IT ON THIS FORM. CAREFULLY TEAR IT OUT, FOLD IT AND DROP IT IN THE MAIL.</i></p>		SOMETHING WRONG WITH PUBLICATION	
		FROM: (PRINT YOUR UNIT'S COMPLETE ADDRESS)	
		DATE SENT	
PUBLICATION NUMBER		PUBLICATION DATE	PUBLICATION TITLE
IN THIS SPACE, TELL WHAT IS WRONG AND WHAT SHOULD BE DONE ABOUT IT.			
BE EXACT PIN-POINT WHERE IT IS			
PAGE NO.	PARA-GRAPH	FIGURE NO.	TABLE NO.
PRINTED NAME, GRADE OR TITLE AND TELEPHONE NUMBER		SIGN HERE	

The Metric System and Equivalents

Linear Measure

1 centimeter = 10 millimeters = .39 inch
 1 decimeter = 10 centimeters = 3.94 inches
 1 meter = 10 decimeters = 39.37 inches
 1 dekameter = 10 meters = 32.8 feet
 1 hectometer = 10 dekameters = 328.08 feet
 1 kilometer = 10 hectometers = 3,280.8 feet

Weights

1 centigram = 10 milligrams = .15 grain
 1 decigram = 10 centigrams = 1.54 grains
 1 gram = 10 decigrams = .035 ounce
 1 decagram = 10 grams = .35 ounce
 acres
 1 hectogram = 10 decagrams = 3.52 ounces
 1 kilogram = 10 hectograms = 2.2 pounds
 1 quintal = 100 kilograms = 220.46 pounds
 1 metric ton = 10 quintals = 1.1 short tons

Liquid Measure

1 centiliter = 10 milliliters = .34 fl. ounce
 1 deciliter = 10 centiliters = 3.38 fl. ounces
 1 liter = 10 deciliters = 33.81 fl. ounces
 1 dekaliter = 10 liters = 2.64 gallons
 1 hectoliter = 10 dekaliters = 26.42 gallons
 1 kiloliter = 10 hectoliters = 264.18 gallons

Square Measure

1 sq. centimeter = 100 sq. millimeters = .155 sq. inch
 1 sq. decimeter = 100 sq. centimeters = 15.5 sq. inches
 1 sq. meter (centare) = 100 sq. decimeters = 10.76 sq. feet
 1 sq. dekameter (are) = 100 sq. meters = 1,076.4 sq. feet
 1 sq. hectometer (hectare) = 100 sq. dekameters = 2.47
 1 sq. kilometer = 100 sq. hectometers = .386 sq. mile

Cubic Measure

1 cu. centimeter = 1000 cu. millimeters = .06 cu. inch
 1 cu. decimeter = 1000 cu. centimeters = 61.02 cu. inches
 1 cu. meter = 1000 cu. decimeters = 35.31 cu. feet

Approximate Conversion Factors

<i>To change</i>	<i>To</i>	<i>Multiply by</i>	<i>To change</i>	<i>To</i>	<i>Multiply by</i>
inches	centimeters	2.540	ounce-inches	Newton-meters	.007062
feet	meters	.305	centimeters	inches	.394
yards	meters	.914	meters	feet	3.280
miles	kilometers	1.609	meters	yards	1.094
square inches	square centimeters	6.451	kilometers	miles	.621
square feet	square meters	.093	square centimeters	square inches	.155
square yards	square meters	.836	square meters	square feet	10.764
square miles	square kilometers	2.590	square meters	square yards	1.196
acres	square hectometers	.405	square kilometers	square miles	.386
cubic feet	cubic meters	.028	square hectometers	acres	2.471
cubic yards	cubic meters	.765	cubic meters	cubic feet	35.315
fluid ounces	milliliters	29,573	cubic meters	cubic yards	1.308
pints	liters	.473	milliliters	fluid ounces	.034
quarts	liters	.946	liters	pints	2.113
gallons	liters	3.785	liters	quarts	1.057
ounces	grams	28.349	liters	gallons	.264
pounds	kilograms	.454	grams	ounces	.035
short tons	metric tons	.907	kilograms	pounds	2.205
pound-feet	Newton-meters	1.356	metric tons	short tons	1.102
pound-inches	Newton-meters	.11296			

Temperature (Exact)

°F	Fahrenheit	5/9 (after	Celsius	°C
	temperature	subtracting 32)	temperature	

PIN: 072328-000